



Brida neumática CPL80

Pneumatic clamp CPL80

Características principales:

- Flancos de aluminio
- Mecanismo de accionamiento de palanca
- Ángulo de apertura fácilmente ajustable
- Comprobación del PIN para verificar la posición final
- Brazos de hierro y aluminio versátiles V y H
- 4 áreas de montaje (frente, parte posterior y en lados)
- Diámetro del cilindro neumático: 80 mm
- 2 puertos de conexión G1/4"
- Interruptor de límite inductivo (conexión M12x1)
- Comando manual

Main characteristics:

- Aluminum flanks
- Toggle action mechanism
- Opening angle easily adjustable
- Checking pin for verifying the end position
- Versatile iron steel arms V and H
- 4 mounting areas (front, back, on the sides)
- Pneumatic cylinder bore: 80 mm
- 2 feeding ports G1/4"
- Inductive proximity switch (connection M12x1)
- Hand lever

[PDF](#)

[3D Step](#)

[INDEX](#)

Índice.





Index.

| Página Page | Descripción Description | |
|----------------|--|---|
| 1 | Características principales / Main characteristics | |
| 2 | Ejemplo de pedido / Ordering example | |
| 3 - 4 | Página dimensional Dimensional page | CPL80-V1... / CPL80-H1... |
| 5 - 6 | | CPL80-V1...S / CPL80-H1...S |
| 7 - 8 | | CPL80-V1CDS / CPL80-H1CDS |
| 9 - 10 | | CPL80-V1CDSS / CPL80-H1CDSS |
| 11 - 12 | | CPL80-V3... / CPL80-H3... |
| 13 - 14 | | CPL80-V3...S / CPL80-H3...S |
| 15 - 16 | | CPLM80 V1... / CPLM80 H1... |
| 17 - 18 | | CPLM80 V1...S / CPLM80 H1...S |
| 19 - 20 | | CPLM80 V3... / CPLM80 H3... |
| 21 - 22 | | CPLM80 V3...S / CPLM80 H3...S |
| 23 | Diagramas / Diagrams | |
| 24 | Diagramas Diagrams | Interruptor de proximidad inductivo M12 M12 Inductive proximity switch |
| | | Diagrama neumático/ Pneumatic plan |
| 25 - 26 | Instrucciones de operación Operating instructions | Cambio de ángulo de apertura Opening angle change |
| 26 - 27 | Piezas de repuesto / Spare parts | |
| 27 | Notas / Notes | |



Ejemplo de pedido.

Ordering example.

| CPL80 | LA | V1C | I1 | G | - | 107 | | | | | | | | | | | | | | | | | | | | | | | | | | | | | | | | | | | | | | | | | | | | | | | | | | | | | | | | | | | | | | | | |
|--|---|--|---|--|---|----------|--------------|-------|--|--|--------|--|--|------------|---------|----------|------------|---------|----------|-------|----|------|------|----|------|------|-------|----|-------|----|------|------|----|------|------|-------|----|------|------|----|------|------|--------|----|-----|-----|----|-----|-----|--------|----|-----|-----|----|-----|-----|--------|----|-----|-----|----|-----|-----|--------|----|-----|-----|----|-----|-----|
| <p>Modelo y diámetro del cilindro: Model and cylinder bore CPL80 Brida estándar CPL D. del cilindro Ø80mm standard clamp CPL cylinder bore Ø80mm</p> <p>CPLM80 Brida estándar CPL con cilindro de palanca manual Ø80mm standard clamp CPL with hand lever cylinder bore Ø80mm</p>  | <p>Posición de la palanca de mano (especificar solo para tipo CPLM...) Hand lever position: (specify only for CPLM... type)</p> <p>LX: Predisposición de la palanca lever arrangement</p> <p>LA: Palanca izquierda left lever</p> <p>LB: Palanca derecha right lever</p>  | <p>Interruptor de proximidad: Proximity switch:</p> <p>X: Sin interruptor de proximidad without proximity switch</p> <p>I1: Interruptor de proximidad inductivo VEP (0°) inductive proximity switch VEP standard (0°)</p> <p>I2: interruptor de proximidad inductivo VEP (90°) inductive proximity switch VEP (90°)</p>  | <p>Tipo de brazo: Type of arm:</p> <p>XXX: Sin brazo without arm</p> <p>V1C, V1D e V1S (ver pag. 3) (see page 3)</p> <p>H1C, H1D e H1S (ver pag. 4) (see page 4)</p> <p>V1CS, V1DS e V1SS (ver pag. 5) (see page 5)</p> <p>H1CS, H1DS e H1SS (ver pag. 6) (see page 6)</p> <p>V1CDS (ver pag. 7) (see page 7)</p> <p>H1CDS (ver pag. 8) (see page 8)</p> <p>V1CDSS (ver pag. 9) (see page 9)</p> <p>H1CDSS (ver pag. 10) (see page 10)</p> <p>V3C, V3D e V3S (ver pag. 11) (see page 11)</p> <p>H3C, H3D e H3S (ver pag. 12) (see page 12)</p> <p>V3CS, V3DS e V3SS (ver pag. 13) (see page 13)</p> <p>H3CS, H3DS e H3SS (ver pag. 14) (see page 14)</p> <p><u>NOTA: Es posible transformar la brida V... en el tipo H... simplemente cambiando la posición del brazo</u> <u>NOTE: It's possible to transform the clamp type V... into the type H... simply changing the arm position.</u></p>  | <p>Tipo de puertos de alimentación: Feeding ports type:</p> <p>G: Puerto tipo G 1/4" ports type G 1/4"</p> <p>N: Puerto tipo 1/4" NPT ports type 1/4" NPT</p>  | <p>Ángulo de apertura ajustable: Adjustable opening angle:</p> <table border="1" style="width: 100%; border-collapse: collapse;"> <thead> <tr style="background-color: #0070C0; color: white;"> <th rowspan="2">Tipo Type</th> <th colspan="3">CPL80</th> <th colspan="3">CPLM80</th> </tr> <tr style="background-color: #0070C0; color: white;"> <th>de from</th> <th>a to</th> <th>Estandar</th> <th>de from</th> <th>a to</th> <th>Estandar</th> </tr> </thead> <tbody> <tr> <td>V1...</td> <td rowspan="2">3°</td> <td rowspan="2">135°</td> <td rowspan="2">122°</td> <td>3°</td> <td rowspan="2">122°</td> <td rowspan="2">122°</td> </tr> <tr> <td>V3...</td> <td>3°</td> </tr> <tr> <td>H1...</td> <td>3°</td> <td>103°</td> <td>103°</td> <td>3°</td> <td>103°</td> <td>103°</td> </tr> <tr> <td>H3...</td> <td>3°</td> <td>117°</td> <td>117°</td> <td>3°</td> <td>117°</td> <td>117°</td> </tr> <tr> <td>V1...S</td> <td>3°</td> <td>13°</td> <td>13°</td> <td>3°</td> <td>13°</td> <td>13°</td> </tr> <tr> <td>V3...S</td> <td>3°</td> <td>29°</td> <td>29°</td> <td>3°</td> <td>29°</td> <td>29°</td> </tr> <tr> <td>H1...S</td> <td>3°</td> <td>72°</td> <td>72°</td> <td>3°</td> <td>72°</td> <td>72°</td> </tr> <tr> <td>H3...S</td> <td>3°</td> <td>58°</td> <td>58°</td> <td>3°</td> <td>58°</td> <td>58°</td> </tr> </tbody> </table> <p>Si no se indica, la abrazadera se proporcionará con el ángulo de apertura estándar. If not indicated, the clamp will be provided with the standard opening angle.</p> | | Tipo Type | CPL80 | | | CPLM80 | | | de from | a to | Estandar | de from | a to | Estandar | V1... | 3° | 135° | 122° | 3° | 122° | 122° | V3... | 3° | H1... | 3° | 103° | 103° | 3° | 103° | 103° | H3... | 3° | 117° | 117° | 3° | 117° | 117° | V1...S | 3° | 13° | 13° | 3° | 13° | 13° | V3...S | 3° | 29° | 29° | 3° | 29° | 29° | H1...S | 3° | 72° | 72° | 3° | 72° | 72° | H3...S | 3° | 58° | 58° | 3° | 58° | 58° |
| Tipo Type | CPL80 | | | CPLM80 | | | | | | | | | | | | | | | | | | | | | | | | | | | | | | | | | | | | | | | | | | | | | | | | | | | | | | | | | | | | | | | | | | |
| | de from | a to | Estandar | de from | a to | Estandar | | | | | | | | | | | | | | | | | | | | | | | | | | | | | | | | | | | | | | | | | | | | | | | | | | | | | | | | | | | | | | | | |
| V1... | 3° | 135° | 122° | 3° | 122° | 122° | | | | | | | | | | | | | | | | | | | | | | | | | | | | | | | | | | | | | | | | | | | | | | | | | | | | | | | | | | | | | | | | |
| V3... | | | | 3° | | | | | | | | | | | | | | | | | | | | | | | | | | | | | | | | | | | | | | | | | | | | | | | | | | | | | | | | | | | | | | | | | | |
| H1... | 3° | 103° | 103° | 3° | 103° | 103° | | | | | | | | | | | | | | | | | | | | | | | | | | | | | | | | | | | | | | | | | | | | | | | | | | | | | | | | | | | | | | | | |
| H3... | 3° | 117° | 117° | 3° | 117° | 117° | | | | | | | | | | | | | | | | | | | | | | | | | | | | | | | | | | | | | | | | | | | | | | | | | | | | | | | | | | | | | | | | |
| V1...S | 3° | 13° | 13° | 3° | 13° | 13° | | | | | | | | | | | | | | | | | | | | | | | | | | | | | | | | | | | | | | | | | | | | | | | | | | | | | | | | | | | | | | | | |
| V3...S | 3° | 29° | 29° | 3° | 29° | 29° | | | | | | | | | | | | | | | | | | | | | | | | | | | | | | | | | | | | | | | | | | | | | | | | | | | | | | | | | | | | | | | | |
| H1...S | 3° | 72° | 72° | 3° | 72° | 72° | | | | | | | | | | | | | | | | | | | | | | | | | | | | | | | | | | | | | | | | | | | | | | | | | | | | | | | | | | | | | | | | |
| H3...S | 3° | 58° | 58° | 3° | 58° | 58° | | | | | | | | | | | | | | | | | | | | | | | | | | | | | | | | | | | | | | | | | | | | | | | | | | | | | | | | | | | | | | | | |



CPL80 H1...

Brida, D.80, Varios ángulos de operación, brazo horizontal, desplazamiento 20
Clamp, D.80, Vario Op. Angle, Horizontal arm, Offset 20

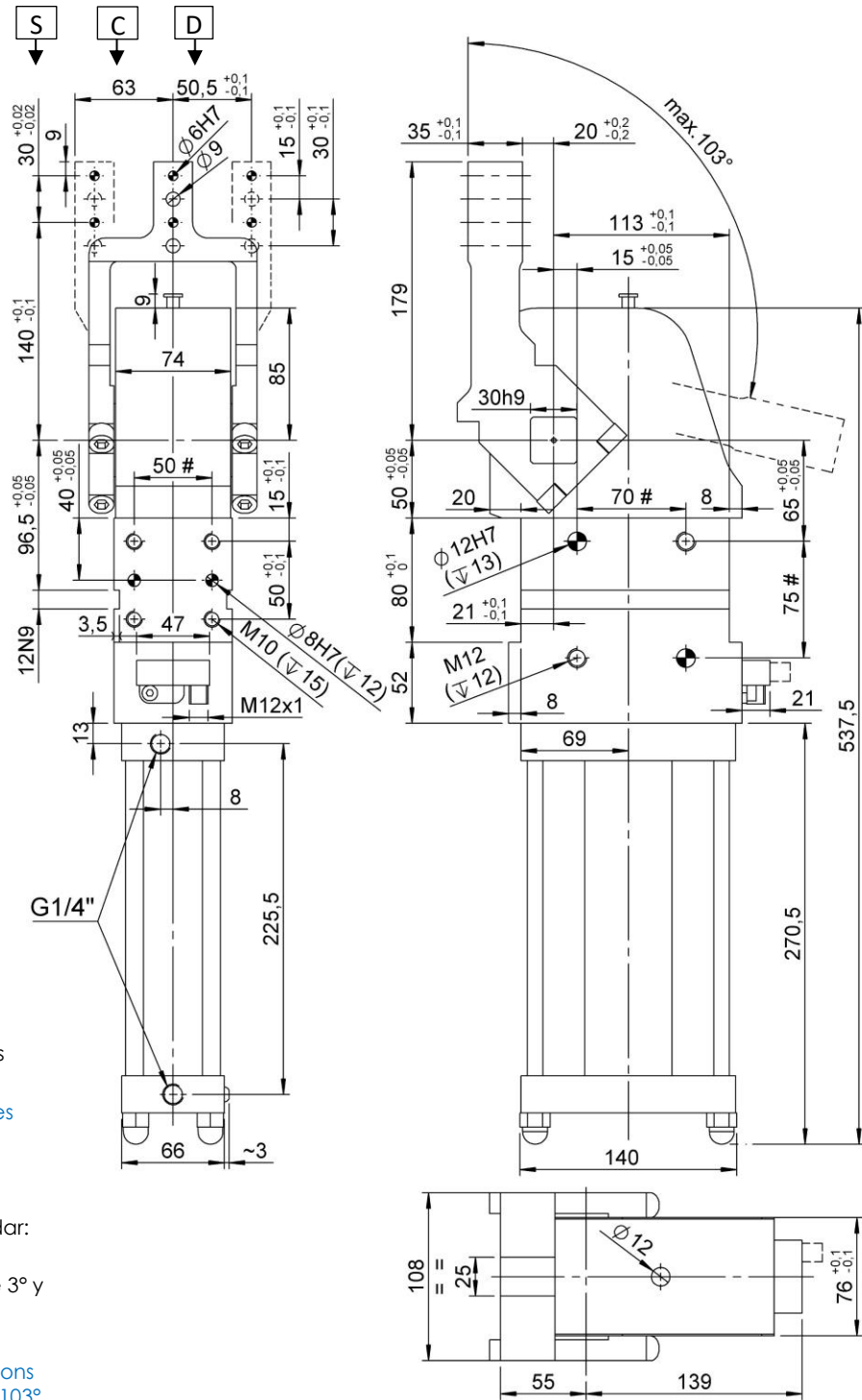

Válvulas de retención del acelerador externas debe proporcionarse en el conjunto. No están incluidos en la entrega.

External throttle check valves must be provided on the assembly. They are not included in the delivery.

Ángulos de apertura estándar: ajustable en 25 posiciones diferentes en un rango entre 3° y 103°.

Standard opening angles: settable in 25 different positions in a range between 3° and 103°.

#Tolerancias: barrenos ± 0.02 , orificios de tornillo ± 0.1

Tolerances: dowel holes ± 0.02 , screw holes ± 0.1

| Tipo Type | Diámetro del cilindro Cylinder bore | Momento de retención Holding moment | Peso Weight | Presión de trabajo Working pressure | Sujeción máxima esfuerzo de torsión Clamping max. torque (5 bar) | Consumo de aire max. Max. air consumption (5 bar) |
|--------------|--|--|----------------|--|---|--|
| | [mm] | [Nm] | [Kg] | [bar] | [Nm] | [l] |
| CPL80 H1... | 80 | 2500 | ~ 14 | 4 – 8 | 1000 | 7,1 |



CPL80 V1...S

Brida, D.80, Varios ángulos de operación, brazo simétrico vertical, desplazamiento 20
 Clamp, D.80, Vario Op. Angle, Vertical symmetric arm, Offset 20

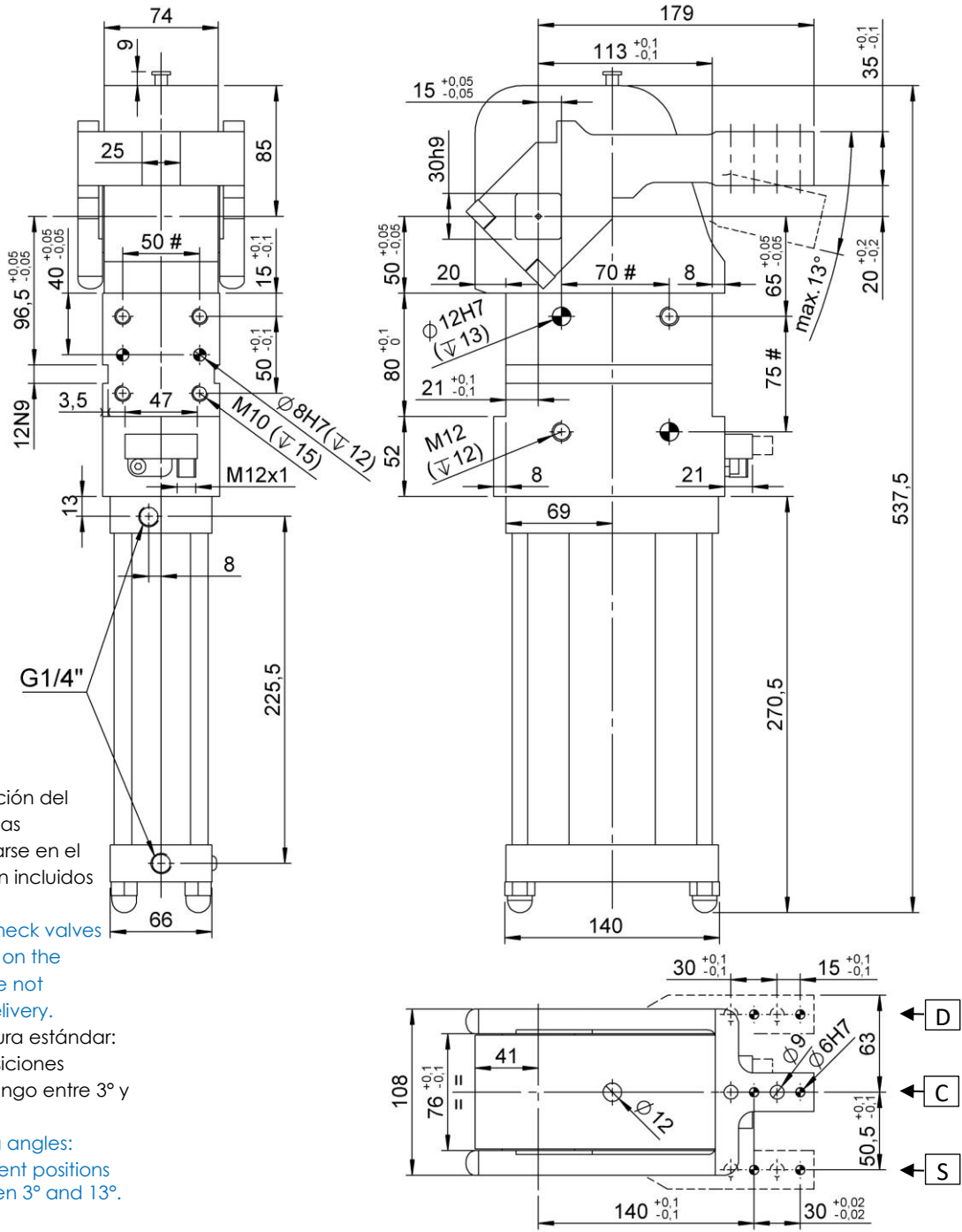

Válvulas de retención del acelerador externas debe proporcionarse en el conjunto. No están incluidos en la entrega.

External throttle check valves must be provided on the assembly. They are not included in the delivery.

Ángulos de apertura estándar: ajustable en 5 posiciones diferentes en un rango entre 3° y 13°.

Standard opening angles: settable in 5 different positions in a range between 3° and 13°.

#Tolerancias: barrenos ± 0.02, orificios de tornillo ± 0.1
 # Tolerances: dowel holes ±0.02, screw holes ±0.1

| Tipo Type | Diámetro del cilindro Cylinder bore | Momento de retención Holding moment | Peso Weight | Presión de trabajo Working pressure | Sujeción máxima esfuerzo de torsión Clamping max. torque (5 bar) | Consumo de aire max. Max. air consumption (5 bar) |
|--------------|--|--|----------------|--|---|--|
| | [mm] | [Nm] | [Kg] | [bar] | [Nm] | [l] |
| CPL80 V1...S | 80 | 2500 | ~ 14 | 4 – 8 | 1000 | 4,7 |



CPL80 H1...S

Brida, D.80, Varios ángulos de operación, brazo simétrico horizontal, desplazamiento 20
 Clamp, D.80, Vario Op. Angle, Horizontal symmetric arm, Offset 20

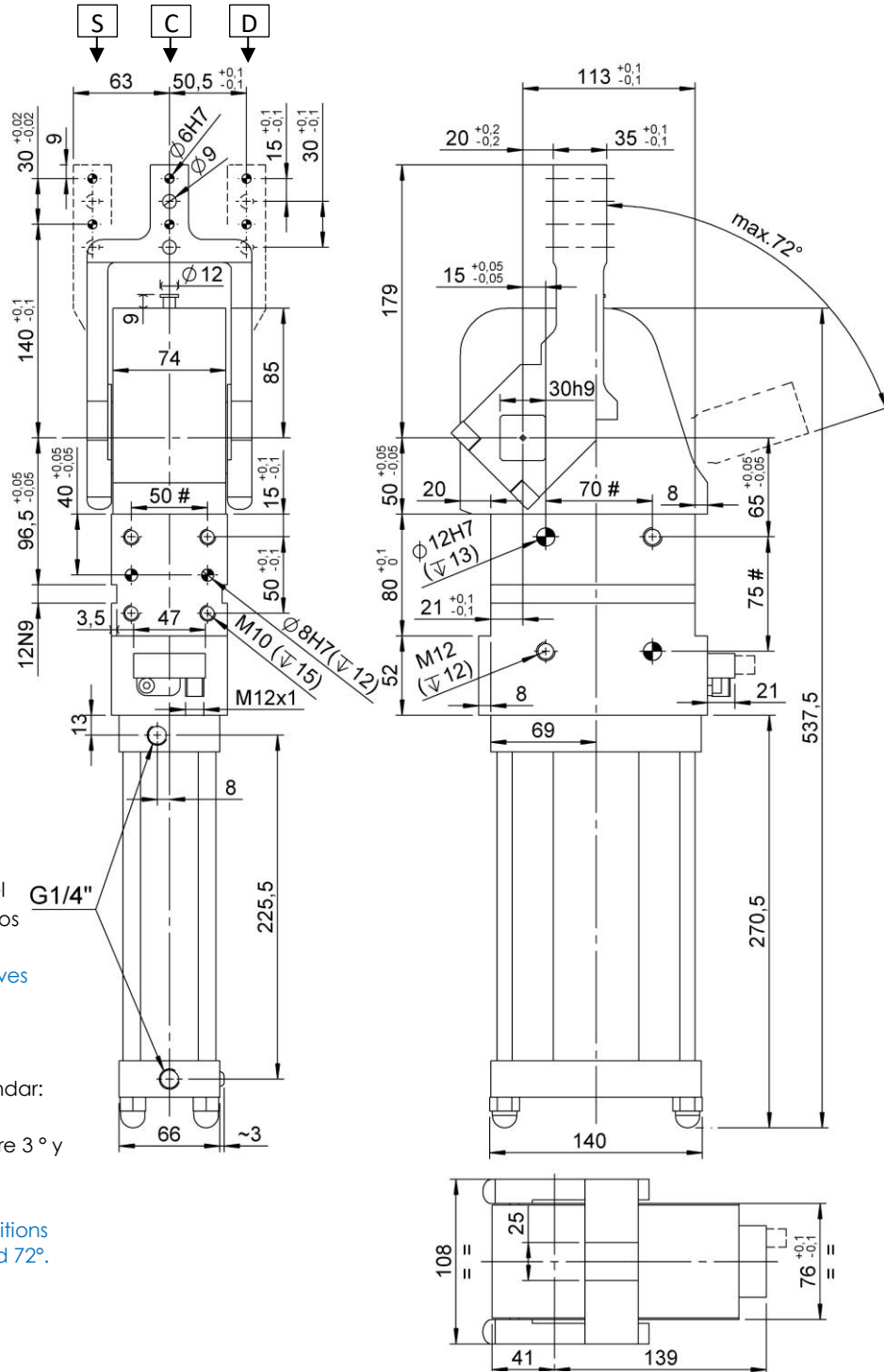

Válvulas de retención del acelerador externas debe proporcionarse en el conjunto. No están incluidos en la entrega.
 External throttle check valves must be provided on the assembly. They are not included in the delivery.
 Ángulos de apertura estándar: ajustable en 18 posiciones diferentes en un rango entre 3° y 72°.

Standard opening angles: settable in 18 different positions in a range between 3° and 72°.

#Tolerancias: barrenos ± 0.02, orificios de tornillo ± 0.1
 # Tolerances: dowel holes ±0.02, screw holes ±0.1

| Tipo Type | Diámetro del cilindro Cylinder bore | Momento de retención Holding moment | Peso Weight | Presión de trabajo Working pressure | Sujeción máxima esfuerzo de torsión Clamping max. torque (5 bar) | Consumo de aire max. Max. air consumption (5 bar) |
|--------------|--|--|----------------|--|---|--|
| | [mm] | [Nm] | [Kg] | [bar] | [Nm] | [l] |
| CPL80 H1...S | 80 | 2500 | ~ 14 | 4 – 8 | 1000 | 6,3 |



CPL80 V1CDS

Brida, D.80, Varios ángulos de operación, brazo CDS vertical, desplazamiento 20
Clamp, D.80, Vario Op. Angle, Vertical CDS arm, Offset 20

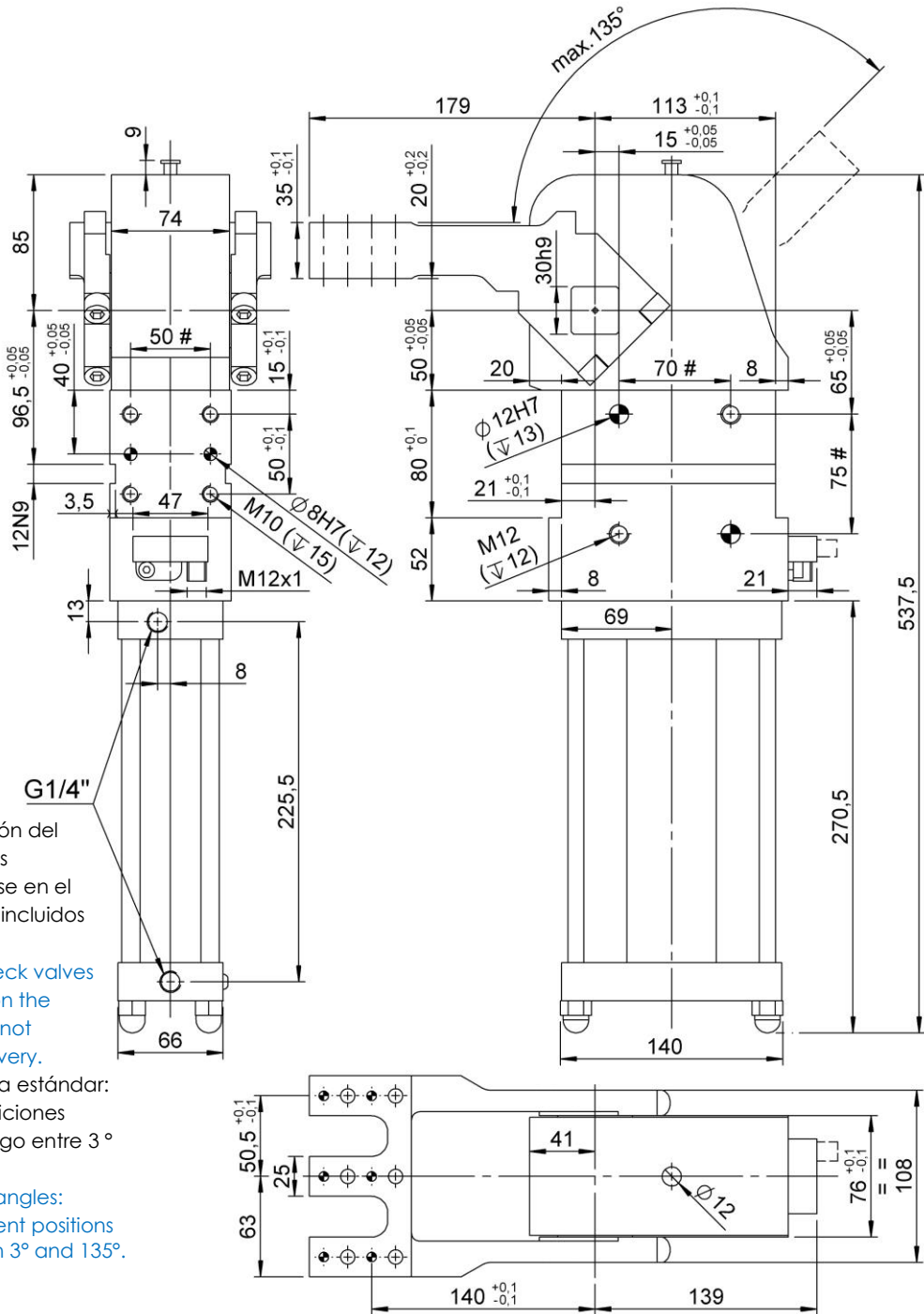

Válvulas de retención del acelerador externas debe proporcionarse en el conjunto. No están incluidos en la entrega.

External throttle check valves must be provided on the assembly. They are not included in the delivery.

Ángulos de apertura estándar: ajustable en 31 posiciones diferentes en un rango entre 3° y 135°.

Standard opening angles: settable in 31 different positions in a range between 3° and 135°.

#Tolerancias: barrenos ± 0.02, orificios de tornillo ± 0.1
Tolerances: dowel holes ±0.02, screw holes ±0.1

| Tipo Type | Diámetro del cilindro Cylinder bore | Momento de retención Holding moment | Peso Weight | Presión de trabajo Working pressure | Sujeción máxima esfuerzo de torsión Clamping max. torque (5 bar) | Consumo de aire max. Max. air consumption (5 bar) |
|--------------|--|--|----------------|--|---|--|
| | [mm] | [Nm] | [Kg] | [bar] | [Nm] | [l] |
| CPL80 V1CDS | 80 | 2500 | ~ 15 | 4 – 8 | 1000 | 7,9 |



CPL80 H1CDS

Brida, D.80, Varios ángulos de operación, brazo CDS horizontal, desplazamiento 20

Clamp, D.80, Vario Op. Angle, Horizontal CDS arm, Offset 20

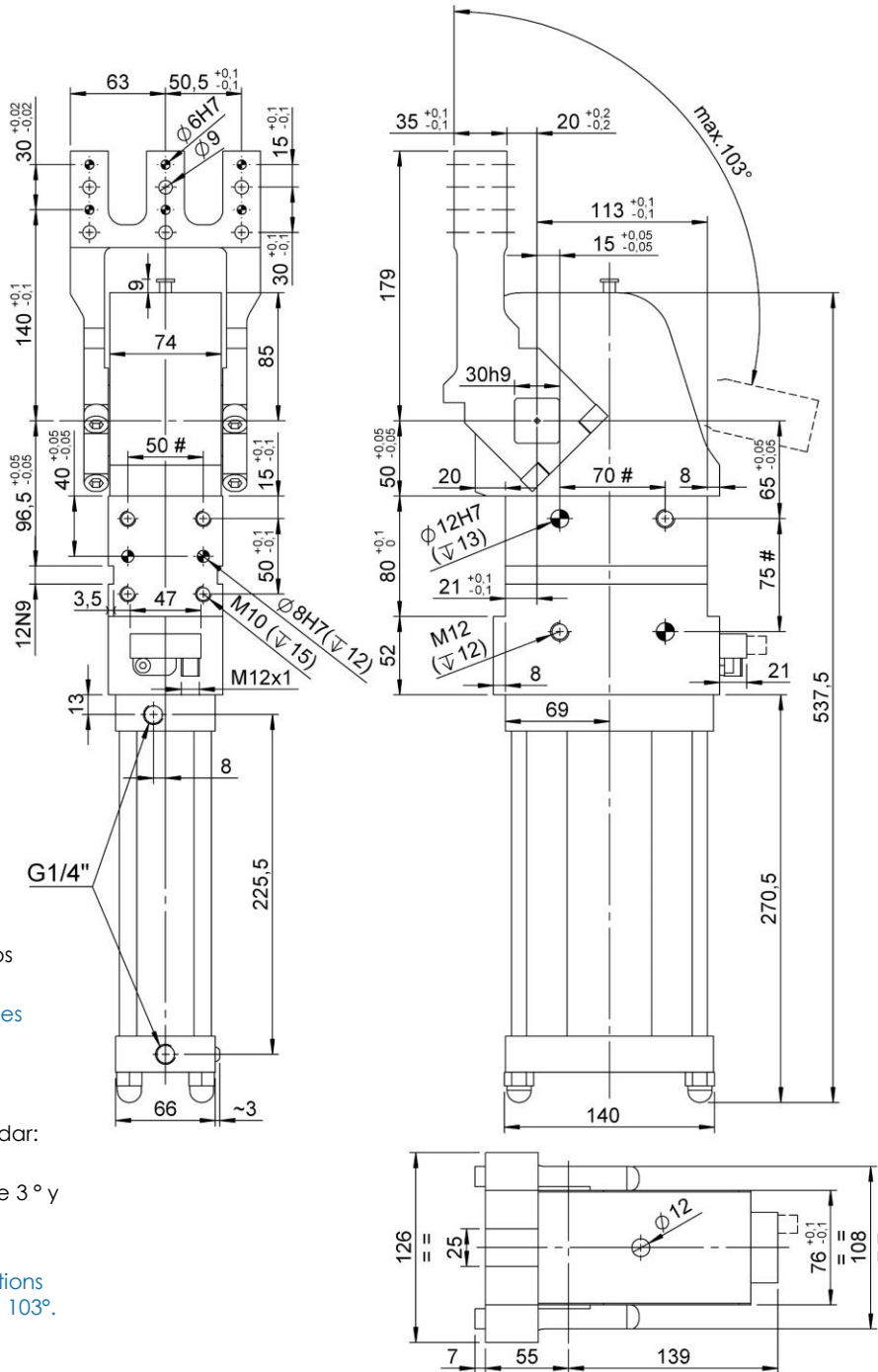

Válvulas de retención del acelerador externas debe proporcionarse en el conjunto. No están incluidos en la entrega.

External throttle check valves must be provided on the assembly. They are not included in the delivery.

Ángulos de apertura estándar: ajustable en 25 posiciones diferentes en un rango entre 3° y 103°.

Standard opening angles: settable in 25 different positions in a range between 3° and 103°.

#Tolerancias: barrenos ± 0.02, orificios de tornillo ± 0.1

Tolerances: dowel holes ±0.02, screw holes ±0.1

| Tipo Type | Diámetro del cilindro Cylinder bore | Momento de retención Holding moment | Peso Weight | Presión de trabajo Working pressure | Sujeción máxima esfuerzo de torsión Clamping max. torque (5 bar) | Consumo de aire max. Max. air consumption (5 bar) |
|--------------|--|--|----------------|--|---|--|
| | [mm] | [Nm] | [Kg] | [bar] | [Nm] | [l] |
| CPL80 H1CDS | 80 | 2500 | ~ 15 | 4 – 8 | 1000 | 7,1 |



CPL80 V1CDSS

Brida, D.80, Varios ángulos de operación, brazo simétrico CDS vertical, desplazamiento 20
Clamp, D.80, Vario Op. Angle, Vertical CDS symm. arm, Offset 20

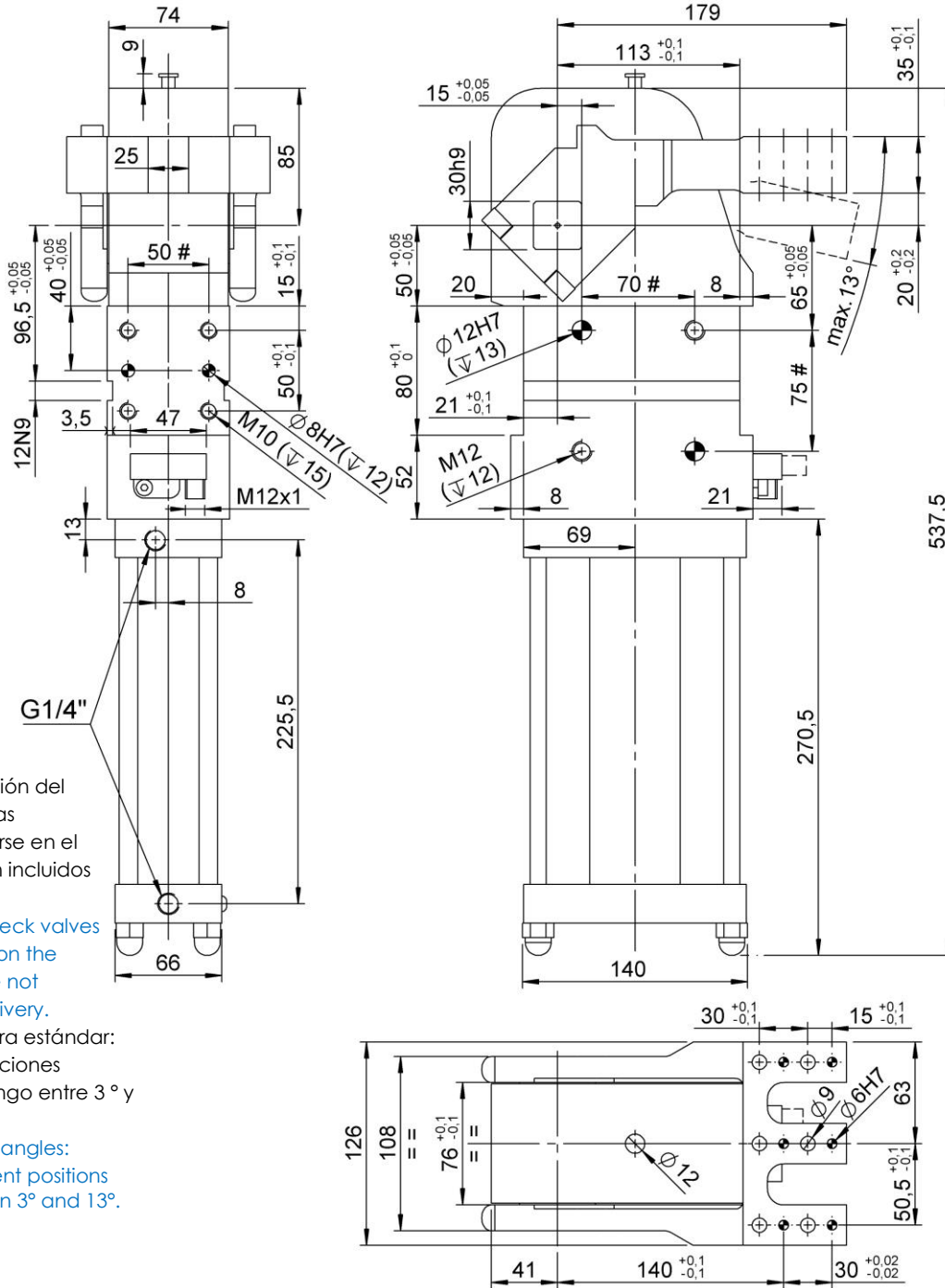

Válvulas de retención del acelerador externas debe proporcionarse en el conjunto. No están incluidos en la entrega.

External throttle check valves must be provided on the assembly. They are not included in the delivery.

Ángulos de apertura estándar: ajustable en 5 posiciones diferentes en un rango entre 3° y 13°.

Standard opening angles: settable in 5 different positions in a range between 3° and 13°.

#Tolerancias: barrenos ± 0.02 , orificios de tornillo ± 0.1

Tolerances: dowel holes ± 0.02 , screw holes ± 0.1

| Tipo Type | Diámetro del cilindro Cylinder bore | Momento de retención Holding moment | Peso Weight | Presión de trabajo Working pressure | Sujeción máxima esfuerzo de torsión Clamping max. torque (5 bar) | Consumo de aire max. Max. air consumption (5 bar) |
|--------------|--|--|----------------|--|---|--|
| | [mm] | [Nm] | [Kg] | [bar] | [Nm] | [l] |
| CPL80 V1CDSS | 80 | 2500 | ~ 15 | 4 – 8 | 1000 | 4,7 |



CPL80 H1CDSS

Brida, D.80, Varios ángulos de operación, brazo simétrico CDS horizontal, desplazamiento 20
 Clamp, D.80, Vario Op. Angle, Horizontal CDS symm. arm, Offset 20

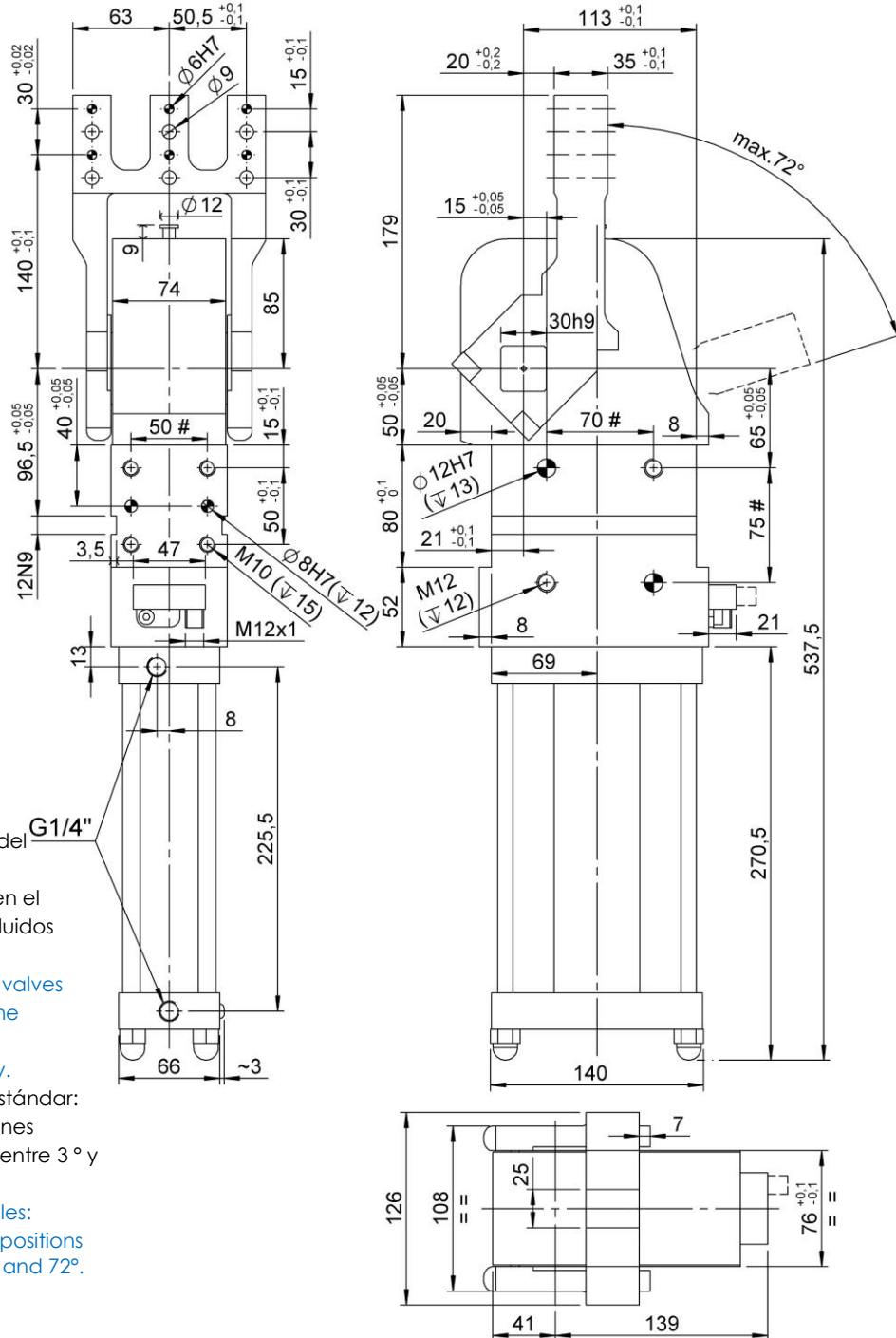

Válvulas de retención del acelerador externas debe proporcionarse en el conjunto. No están incluidos en la entrega.
 External throttle check valves must be provided on the assembly. They are not included in the delivery.
 Ángulos de apertura estándar: ajustable en 18 posiciones diferentes en un rango entre 3° y 72°.
 Standard opening angles: settable in 18 different positions in a range between 3° and 72°.

#Tolerancias: barrenos ± 0.02, orificios de tornillo ± 0.1
 # Tolerances: dowel holes ±0.02, screw holes ±0.1

| Tipo Type | Diámetro del cilindro Cylinder bore | Momento de retención Holding moment | Peso Weight | Presión de trabajo Working pressure | Sujeción máxima esfuerzo de torsión Clamping max. torque (5 bar) | Consumo de aire max. Max. air consumption (5 bar) |
|--------------|--|--|----------------|--|---|--|
| | [mm] | [Nm] | [Kg] | [bar] | [Nm] | [l] |
| CPL80 H1CDSS | 80 | 2500 | ~ 15 | 4 – 8 | 1000 | 6,3 |



CPL80 V3...

Brida, D.80, Varios ángulos de operación, brazo vertical, desplazamiento 45

Clamp, D.80, Vario Op. Angle, Vertical arm, Offset 45

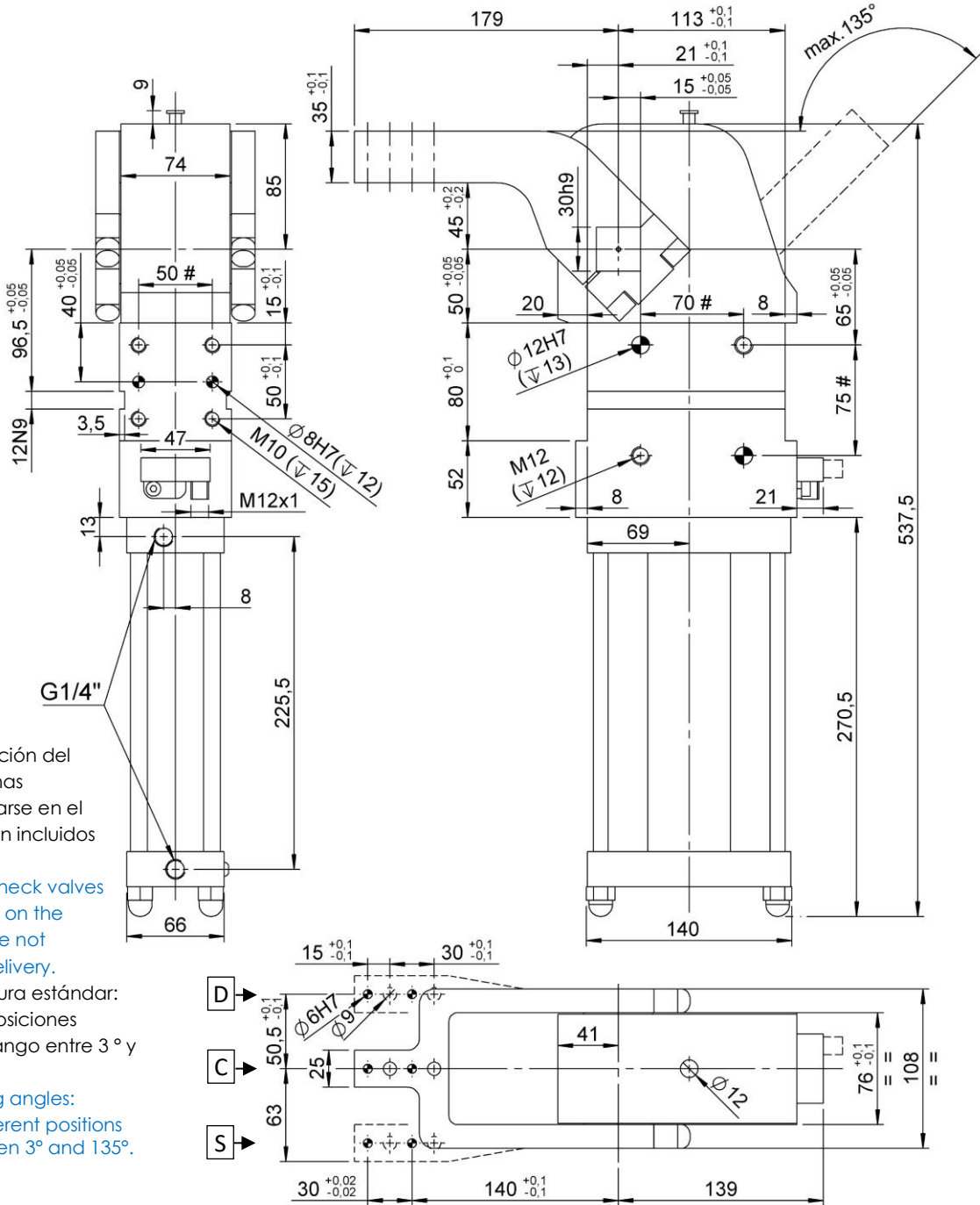

Válvulas de retención del acelerador externas debe proporcionarse en el conjunto. No están incluidos en la entrega.

External throttle check valves must be provided on the assembly. They are not included in the delivery.

Ángulos de apertura estándar: ajustable en 31 posiciones diferentes en un rango entre 3° y 135°.

Standard opening angles: settable in 31 different positions in a range between 3° and 135°.

#Tolerancias: barrenos ± 0.02 , orificios de tornillo ± 0.1

Tolerances: dowel holes ± 0.02 , screw holes ± 0.1

| Tipo Type | Diámetro del cilindro Cylinder bore | Momento de retención Holding moment | Peso Weight | Presión de trabajo Working pressure | Sujeción máxima esfuerzo de torsión Clamping max. torque (5 bar) | Consumo de aire max. Max. air consumption (5 bar) |
|--------------|--|--|----------------|--|---|--|
| | [mm] | [Nm] | [Kg] | [bar] | [Nm] | [l] |
| CPL80 V3... | 80 | 2500 | ~ 14,5 | 4 – 8 | 1000 | 7,9 |



CPL80 H3...

Brida, D.80, Varios ángulos de operación, brazo horizontal, desplazamiento 45
Clamp, D.80, Vario Op. Angle, Horizontal arm, Offset 45

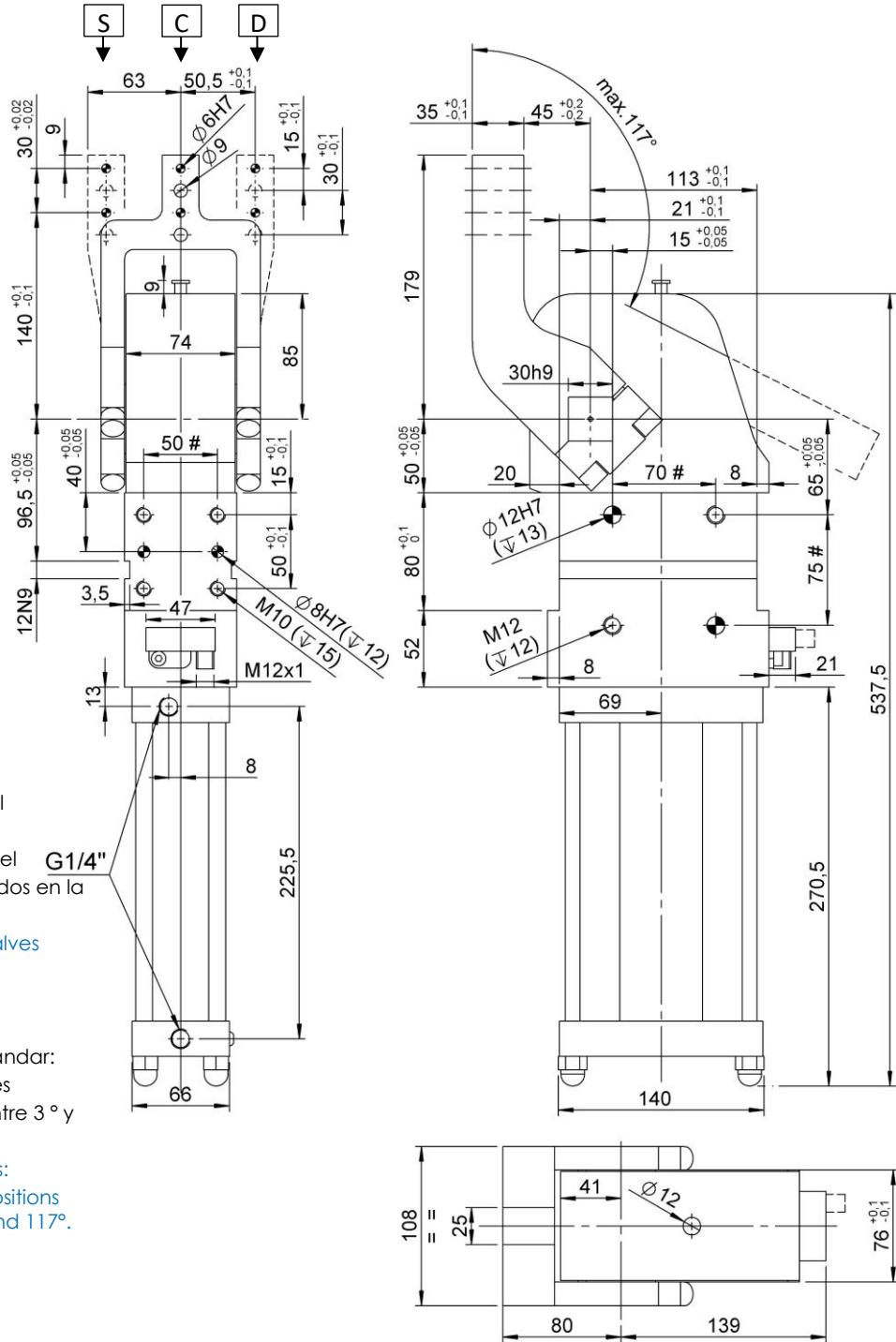

Válvulas de retención del acelerador externas debe proporcionarse en el conjunto. No están incluidos en la entrega.

External throttle check valves must be provided on the assembly. They are not included in the delivery.

Ángulos de apertura estándar: ajustable en 28 posiciones diferentes en un rango entre 3° y 117°.

Standard opening angles: settable in 28 different positions in a range between 3° and 117°.

#Tolerancias: barrenos ± 0.02, orificios de tornillo ± 0.1

Tolerances: dowel holes ±0.02, screw holes ±0.1

| Tipo Type | Diámetro del cilindro Cylinder bore | Momento de retención Holding moment | Peso Weight | Presión de trabajo Working pressure | Sujeción máxima esfuerzo de torsión Clamping max. torque (5 bar) | Consumo de aire max. Max. air consumption (5 bar) |
|--------------|--|--|----------------|--|---|--|
| | [mm] | [Nm] | [Kg] | [bar] | [Nm] | [l] |
| CPL80 H3... | 80 | 2500 | ~ 14,5 | 4 – 8 | 1000 | 7,5 |



CPL80 V3...S

Brida, D.80, Varios ángulos de operación, brazo simétrico vertical, desplazamiento 45
Clamp, D.80, Vario Op. Angle, Vertical symmetric arm, Offset 45

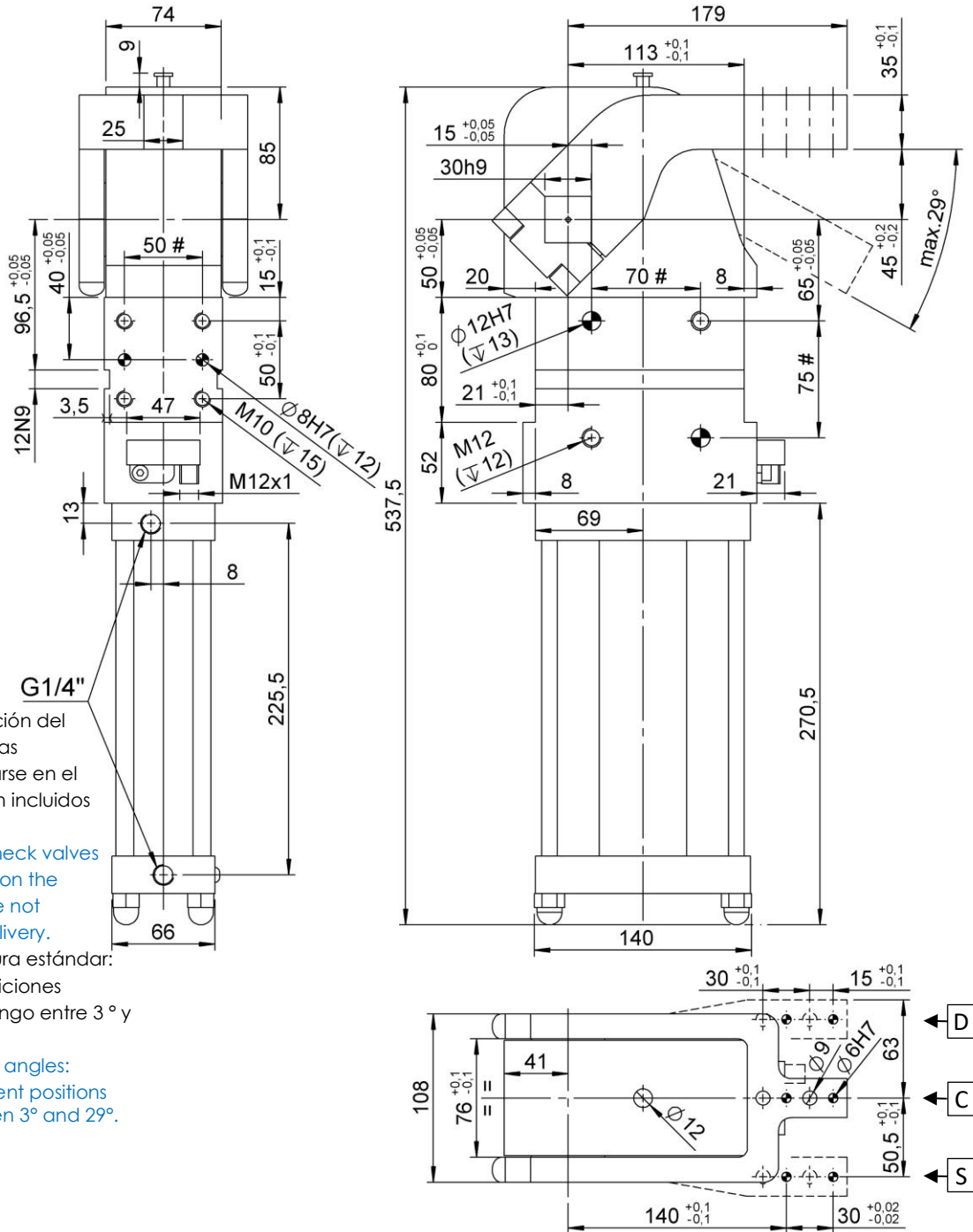

Válvulas de retención del acelerador externas debe proporcionarse en el conjunto. No están incluidos en la entrega.

External throttle check valves must be provided on the assembly. They are not included in the delivery.

Ángulos de apertura estándar: ajustable en 7 posiciones diferentes en un rango entre 3° y 29°.

Standard opening angles: settable in 7 different positions in a range between 3° and 29°.

#Tolerancias: barrenos ± 0.02, orificios de tornillo ± 0.1

Tolerances: dowel holes ±0.02, screw holes ±0.1

| Tipo Type | Diámetro del cilindro Cylinder bore | Momento de retención Holding moment | Peso Weight | Presión de trabajo Working pressure | Sujeción máxima esfuerzo de torsión Clamping max. torque (5 bar) | Consumo de aire max. Max. air consumption (5 bar) |
|--------------|--|--|----------------|--|---|--|
| | [mm] | [Nm] | [Kg] | [bar] | [Nm] | [l] |
| CPL80 V3...S | 80 | 2500 | ~ 14,5 | 4 – 8 | 1000 | 5,2 |



CPL80 H3...S

Brida, D.80, Varios ángulos de operación, brazo simétrico horizontal, desplazamiento 45
Clamp, D.80, Vario Op. Angle, Horizontal symmetric arm, Offset 45

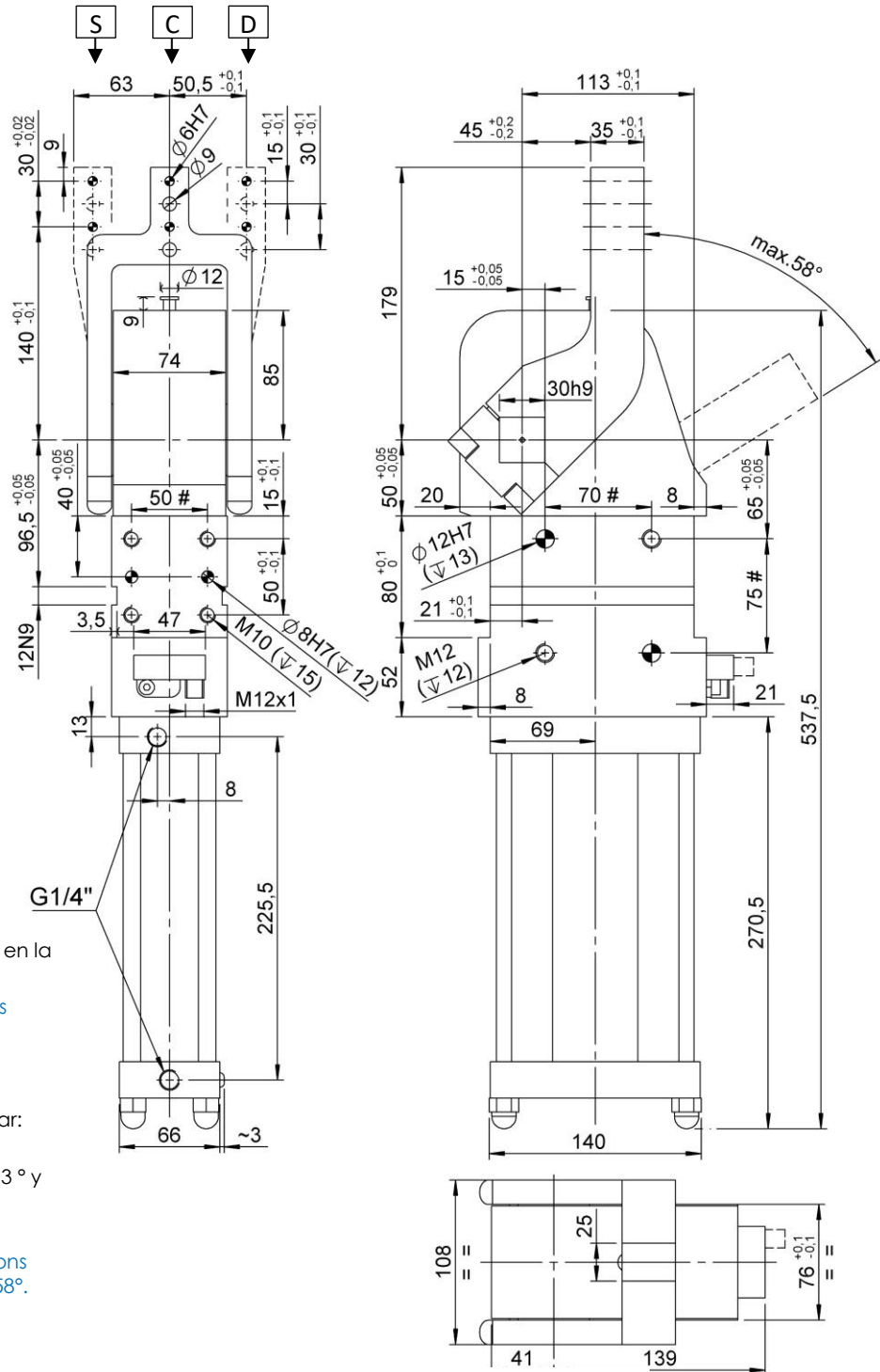

Válvulas de retención del acelerador externas debe proporcionarse en el conjunto. No están incluidos en la entrega.
External throttle check valves must be provided on the assembly. They are not included in the delivery.
Ángulos de apertura estándar: ajustable en 15 posiciones diferentes en un rango entre 3° y 58°.
Standard opening angles: settable in 15 different positions in a range between 3° and 58°.

#Tolerancias: barrenos ± 0.02, orificios de tornillo ± 0.1
Tolerances: dowel holes ±0.02, screw holes ±0.1

| Tipo Type | Diámetro del cilindro Cylinder bore | Momento de retención Holding moment | Peso Weight | Presión de trabajo Working pressure | Sujeción máxima esfuerzo de torsión Clamping max. torque (5 bar) | Consumo de aire max. Max. air consumption (5 bar) |
|--------------|--|--|----------------|--|--|--|
| | [mm] | [Nm] | [Kg] | [bar] | [Nm] | [l] |
| CPL80 H3...S | 80 | 2500 | ~ 14,5 | 4 – 8 | 1000 | 5,9 |



CPLM80L...V1...

Brida, D.80, Varios ángulos de operación, Palanca manual, Brazo vertical, desplazamiento 20
 Clamp, D.80, Vario Op. Angle, Hand Lever, Vert. arm, Offset 20

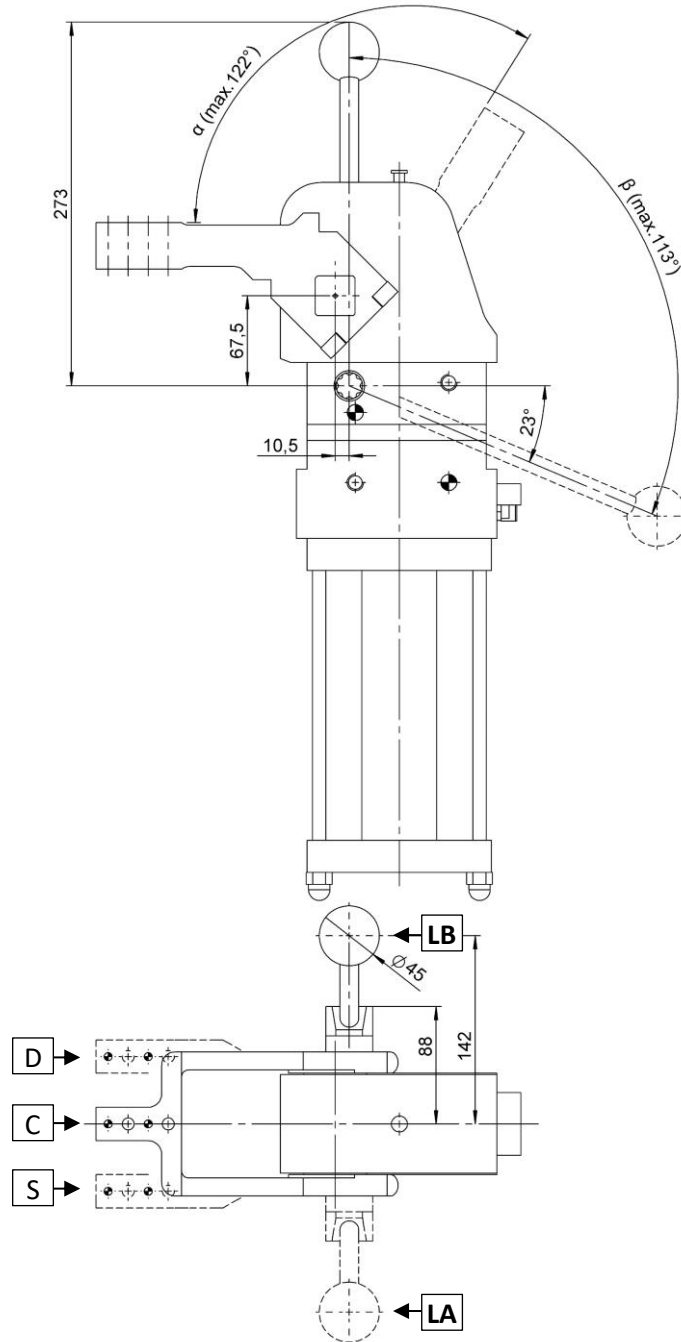

| | | | | | | | | |
|----------|-----|-----|-----|-----|-----|-----|------|------|
| α | 16° | 29° | 43° | 58° | 77° | 90° | 107° | 122° |
| β | 37° | 46° | 55° | 64° | 76° | 86° | 100° | 113° |

Control manual ajustable en pasos de 22,5°
 Manual control adjustable in steps of 22,5°

#Tolerancias: barrenos ± 0.02, orificios de tornillo ± 0.1
 # Tolerances: dowel holes ±0.02, screw holes ±0.1

| Tipo Type | Diámetro del cilindro Cylinder bore | Momento de retención Holding moment | Peso Weight | Presión de trabajo Working pressure | Max. fuerza manual Max. manual force |
|-----------------|--|--|----------------|--|---|
| | [mm] | [Nm] | [Kg] | [bar] | [N] |
| CPLM80L...V1... | 80 | 2500 | ~ 16 | 4 – 8 | 200 |



CPLM80L...H1...

Brida, D.80, Varios ángulos de operación, Palanca manual, Brazo horizontal, desplazamiento 20
Clamp, D.80, Vario Op. Angle, Hand Lever, Horiz. Arm, Offset 20

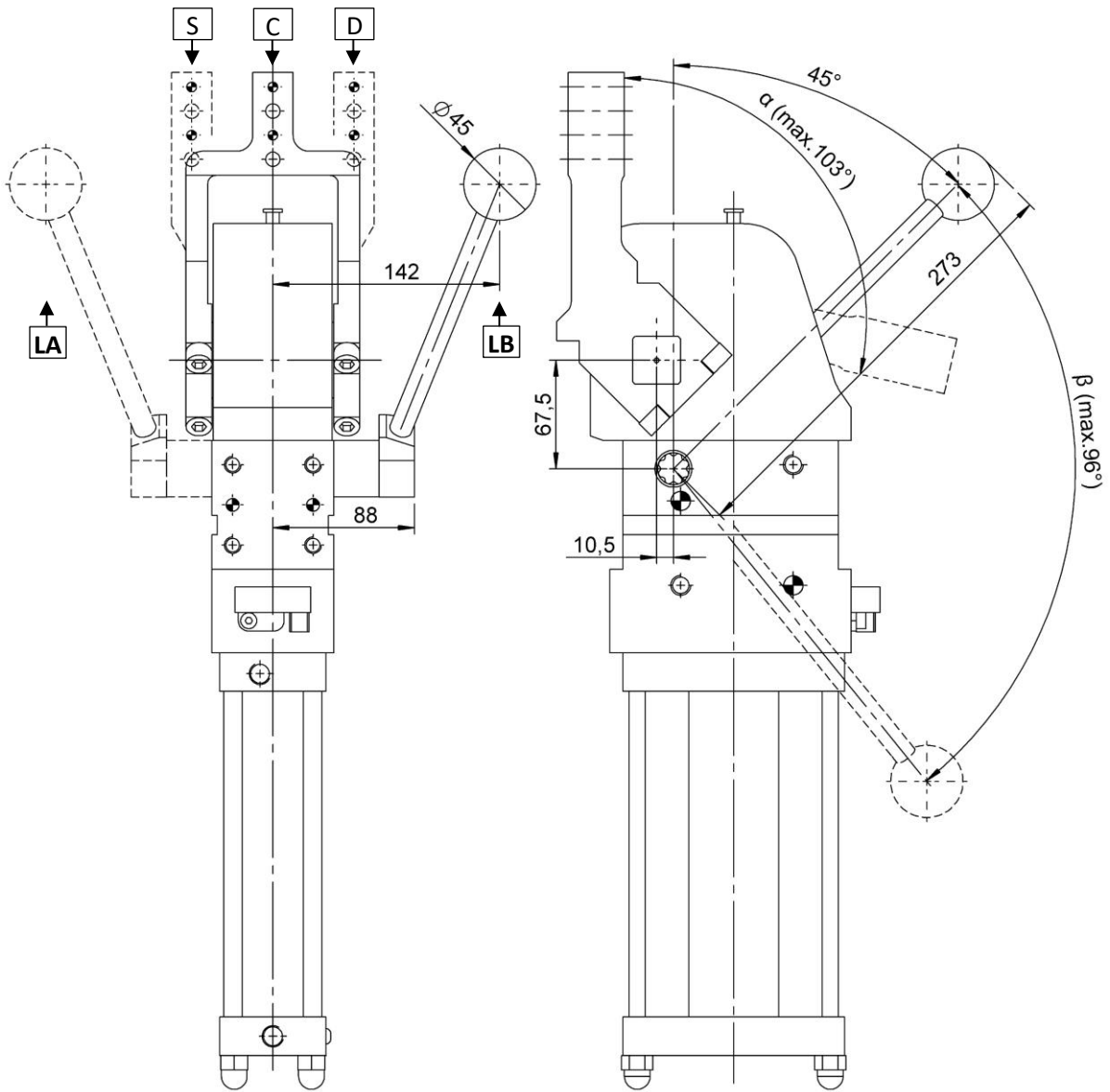

| | | | | | | | |
|----------|-----|-----|-----|-----|-----|-----|------|
| α | 16° | 29° | 43° | 58° | 77° | 90° | 103° |
| β | 37° | 46° | 55° | 64° | 76° | 86° | 96° |

Control manual ajustable en pasos de 22,5°
Manual control adjustable in steps of 22,5°

#Tolerancias: barrenos ± 0.02 , orificios de tornillo ± 0.1

Tolerances: dowel holes ± 0.02 , screw holes ± 0.1

| Tipo Type | Diámetro del cilindro Cylinder bore | Momento de retención Holding moment | Peso Weight | Presión de trabajo Working pressure | Max. fuerza manual Max. manual force |
|-----------------|--|--|----------------|--|---|
| | [mm] | [Nm] | [Kg] | [bar] | [N] |
| CPLM80L...H1... | 80 | 2500 | ~ 16 | 4 – 8 | 200 |



CPLM80L...V1...S

Brida, D.80, Varios ángulos de operación, Palanca manual, Brazo vertical simétrico, desplazamiento 20
Clamp, D.80, Vario Op. Angle, Hand Lever, Vert. Sym., Offset 20

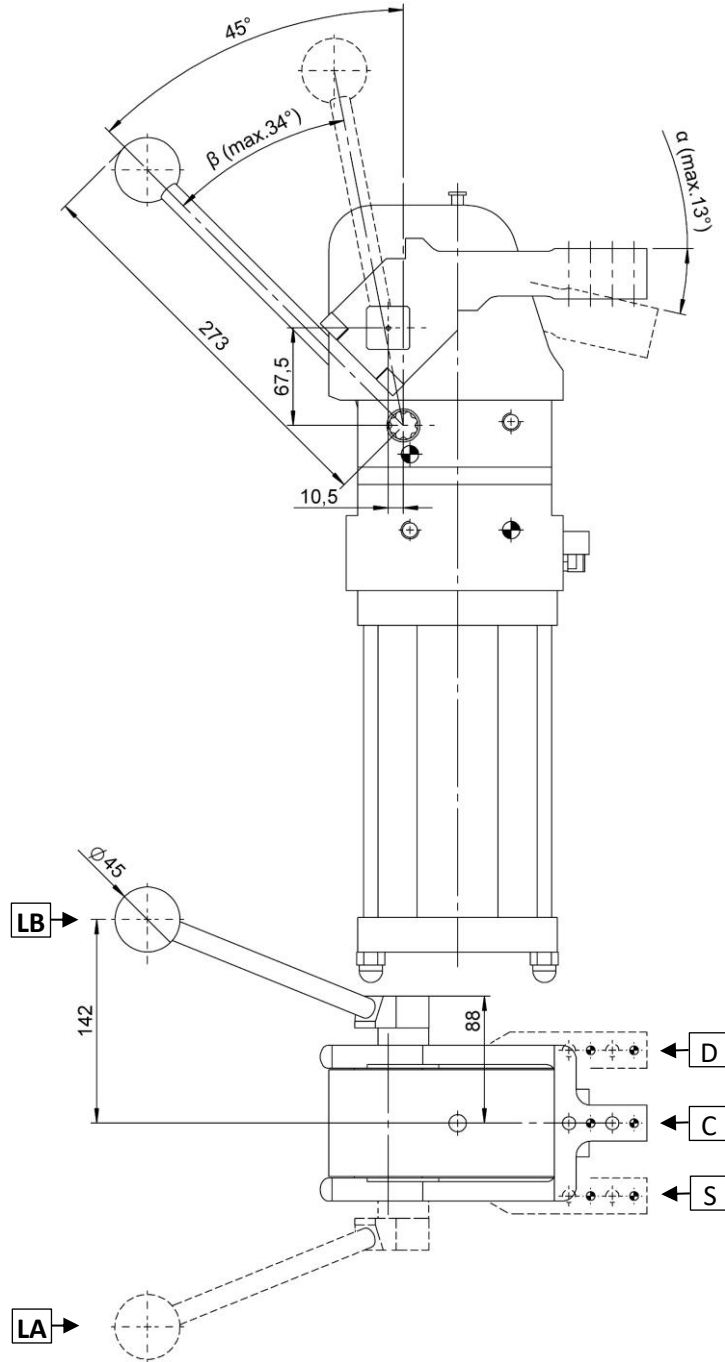

| | |
|----------|-----|
| α | 13° |
| β | 34° |

Control manual ajustable en pasos de 22,5°
Manual control adjustable in steps of 22,5°

#Tolerancias: barrenos ± 0.02 , orificios de tornillo ± 0.1
Tolerances: dowel holes ± 0.02 , screw holes ± 0.1

| Tipo Type | Diámetro del cilindro Cylinder bore | Momento de retención Holding moment | Peso Weight | Presión de trabajo Working pressure | Max. fuerza manual Max. manual force |
|------------------|--|--|----------------|--|---|
| | [mm] | [Nm] | [Kg] | [bar] | [N] |
| CPLM80L...V1...S | 80 | 2500 | ~ 16 | 4 – 8 | 200 |



CPLM80L...H1...S

Brida, D.80, Varios ángulos de operación, Palanca manual, Brazo horizontal simétrico, desplazamiento 20
Clamp, D.80, Vario Op. Angle, Hand Lever, Horiz. Sym., Offset 20

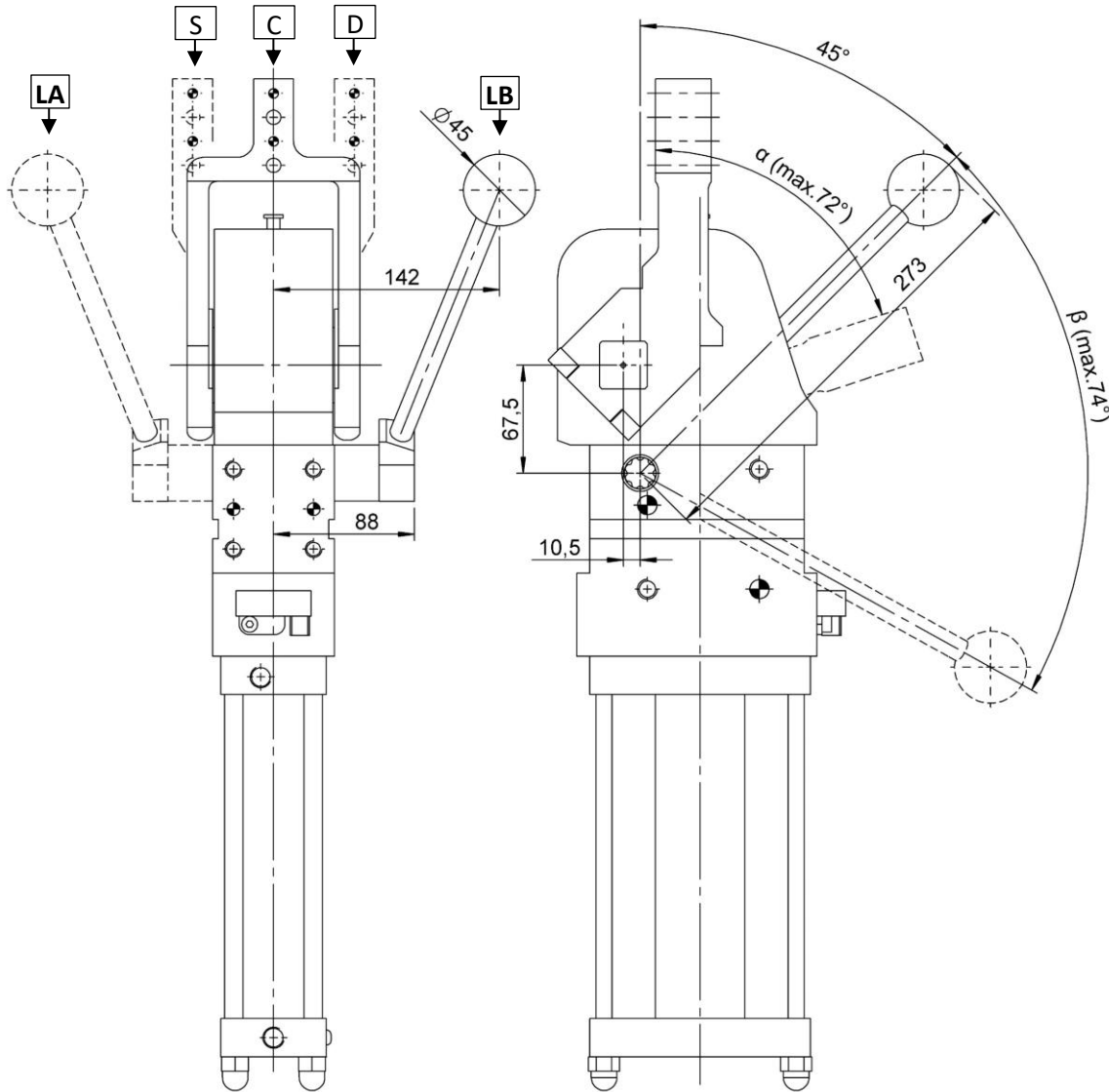

| | | | | | |
|----------|-----|-----|-----|-----|-----|
| α | 16° | 30° | 46° | 58° | 72° |
| β | 37° | 47° | 57° | 63° | 74° |

Control manual ajustable en pasos de 22,5°
Manual control adjustable in steps of 22,5°

#Tolerancias: barrenos ± 0.02 , orificios de tornillo ± 0.1
Tolerances: dowel holes ± 0.02 , screw holes ± 0.1

| Tipo Type | Diámetro del cilindro Cylinder bore | Momento de retención Holding moment | Peso Weight | Presión de trabajo Working pressure | Max. fuerza manual Max. manual force |
|------------------|--|--|----------------|--|---|
| | [mm] | [Nm] | [Kg] | [bar] | [N] |
| CPLM80L...H1...S | 80 | 2500 | ~ 16 | 4 – 8 | 200 |



CPLM80L...V3...

Brida, D.80, Varios ángulos de operación, Palanca manual, Brazo vertical, desplazamiento 45
 Clamp, D.80, Vario Op. Angle, Hand Lever, Vert. arm, Offset 45

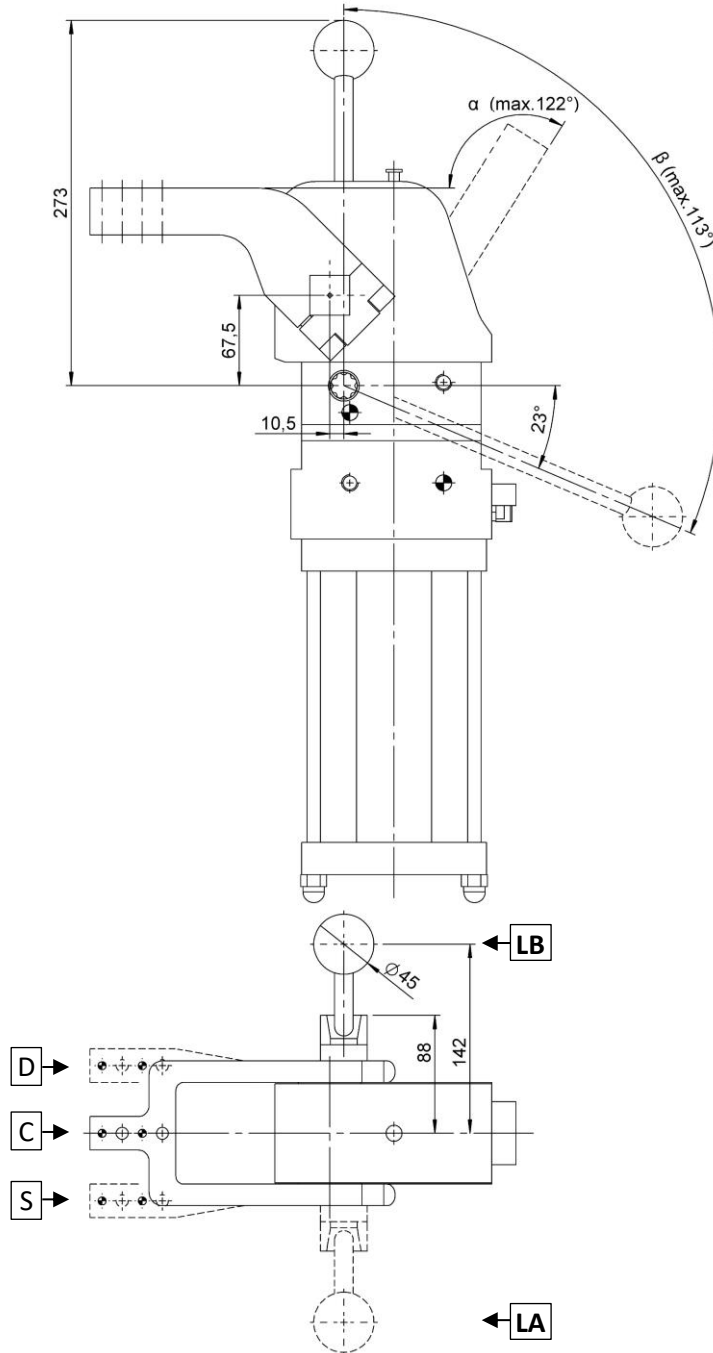

| | | | | | | | | |
|----------|-----|-----|-----|-----|-----|-----|------|------|
| α | 16° | 29° | 43° | 58° | 77° | 90° | 107° | 122° |
| β | 37° | 46° | 55° | 64° | 76° | 86° | 100° | 113° |

Control manual ajustable en pasos de 22,5°
 Manual control adjustable in steps of 22,5°

#Tolerancias: barrenos ± 0.02, orificios de tornillo ± 0.1
 # Tolerances: dowel holes ±0.02, screw holes ±0.1

| Tipo Type | Diámetro del cilindro Cylinder bore | Momento de retención Holding moment | Peso Weight | Presión de trabajo Working pressure | Max. fuerza manual Max. manual force |
|-----------------|--|--|----------------|--|---|
| | [mm] | [Nm] | [Kg] | [bar] | [N] |
| CPLM80L...V3... | 80 | 2500 | ~ 16,5 | 4 – 8 | 200 |



CPLM80L...H3...

Brida, D.80, Varios ángulos de operación, Palanca manual, Brazo horizontal, desplazamiento 45
 Clamp, D.80, Vario Op. Angle, Hand Lever, Horiz. Arm, Offset 45

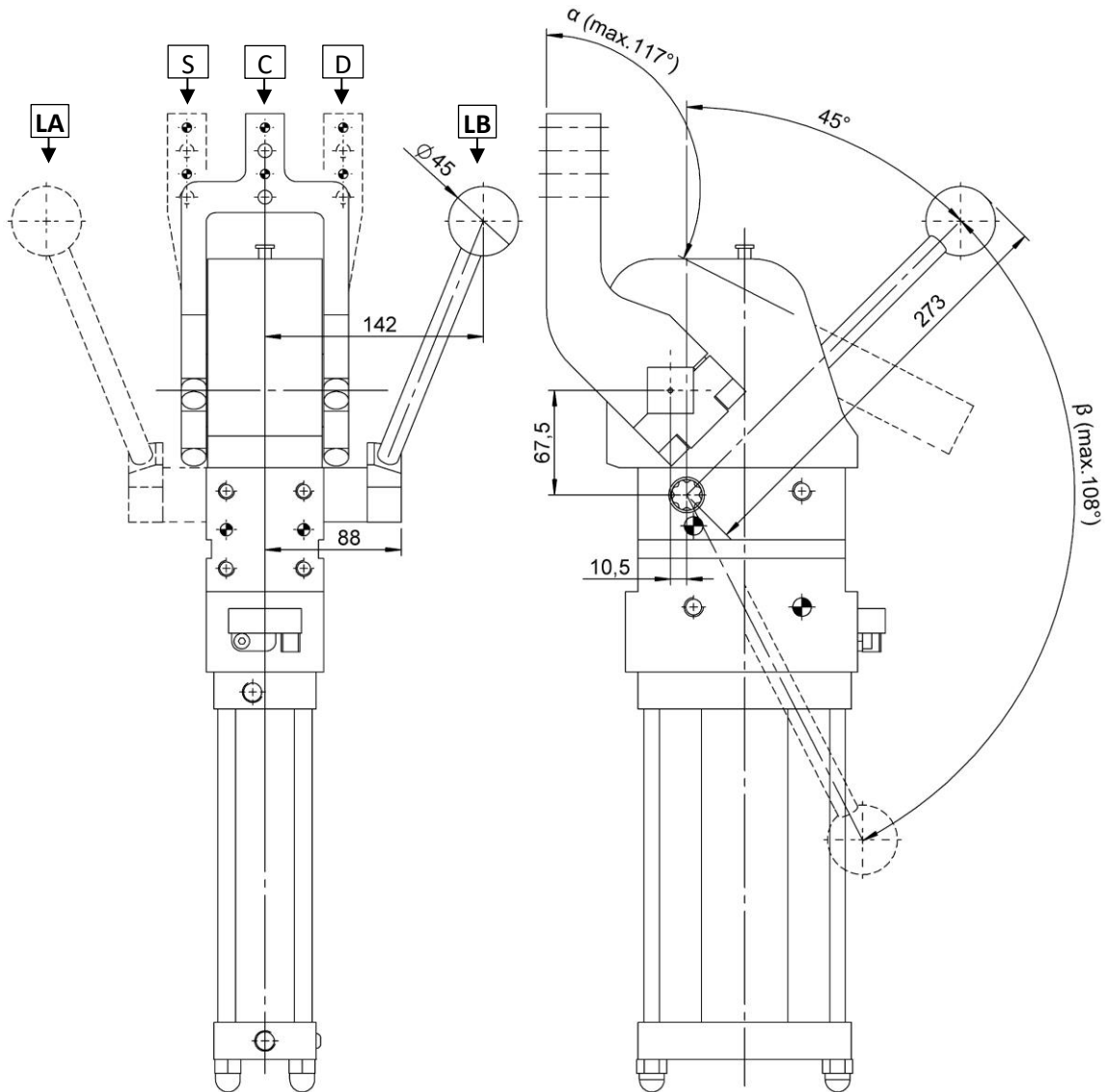

| | | | | | | | | |
|----------|-----|-----|-----|-----|-----|-----|------|------|
| α | 16° | 29° | 43° | 58° | 77° | 90° | 107° | 117° |
| β | 37° | 46° | 55° | 64° | 76° | 86° | 100° | 108° |

Control manual ajustable en pasos de 22,5°
 Manual control adjustable in steps of 22,5°

#Tolerancias: barrenos ± 0.02 , orificios de tornillo ± 0.1
 # Tolerances: dowel holes ± 0.02 , screw holes ± 0.1

| Tipo Type | Diámetro del cilindro Cylinder bore | Momento de retención Holding moment | Peso Weight | Presión de trabajo Working pressure | Max. fuerza manual Max. manual force |
|-----------------|--|--|----------------|--|---|
| | [mm] | [Nm] | [Kg] | [bar] | [N] |
| CPLM80L...H3... | 80 | 2500 | ~ 16,5 | 4 – 8 | 200 |



CPLM80L...V3...S

Brida, D.80, Varios ángulos de operación, Palanca manual, Brazo vertical simétrico, desplazamiento 45
 Clamp, D.80, Vario Op. Angle, Hand Lever, Vert. Sym., Offset 45

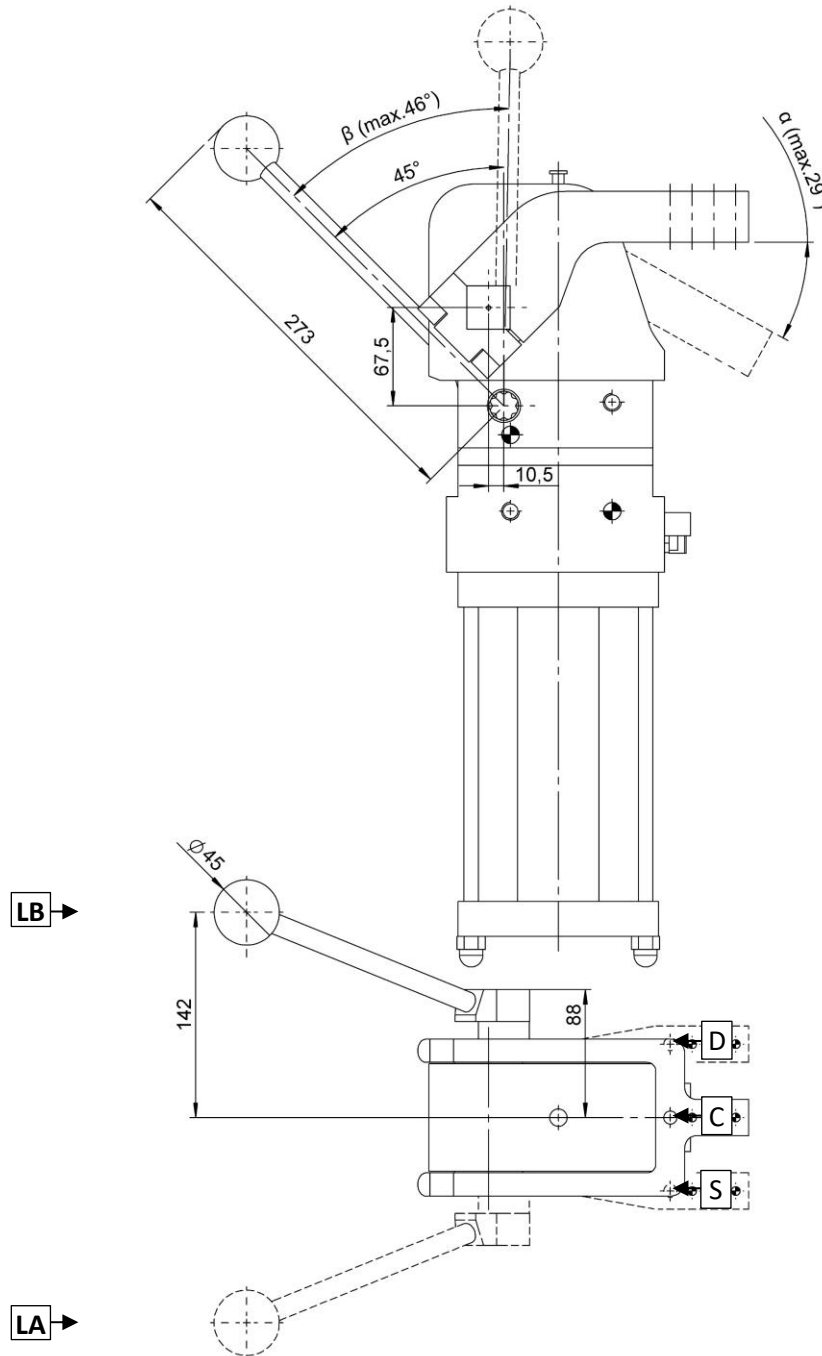

| | | |
|----------|-----|-----|
| α | 16° | 29° |
| β | 37° | 46° |

Control manual ajustable en pasos de 22,5°
 Manual control adjustable in steps of 22,5°

#Tolerancias: barrenos ± 0.02 , orificios de tornillo ± 0.1
 # Tolerances: dowel holes ± 0.02 , screw holes ± 0.1

| Tipo Type | Diámetro del cilindro Cylinder bore | Momento de retención Holding moment | Peso Weight | Presión de trabajo Working pressure | Max. fuerza manual Max. manual force |
|------------------|--|--|----------------|--|---|
| | [mm] | [Nm] | [Kg] | [bar] | [N] |
| CPLM50L...V3...S | 80 | 2500 | ~ 16,5 | 4 – 8 | 200 |



CPLM80L...H3...S

Brida, D.80, Varios ángulos de operación, Palanca manual, Brazo horizontal simétrico, desplazamiento 45
 Clamp, D.80, Vario Op. Angle, Hand Lever, Horiz. Sym., Offset 45

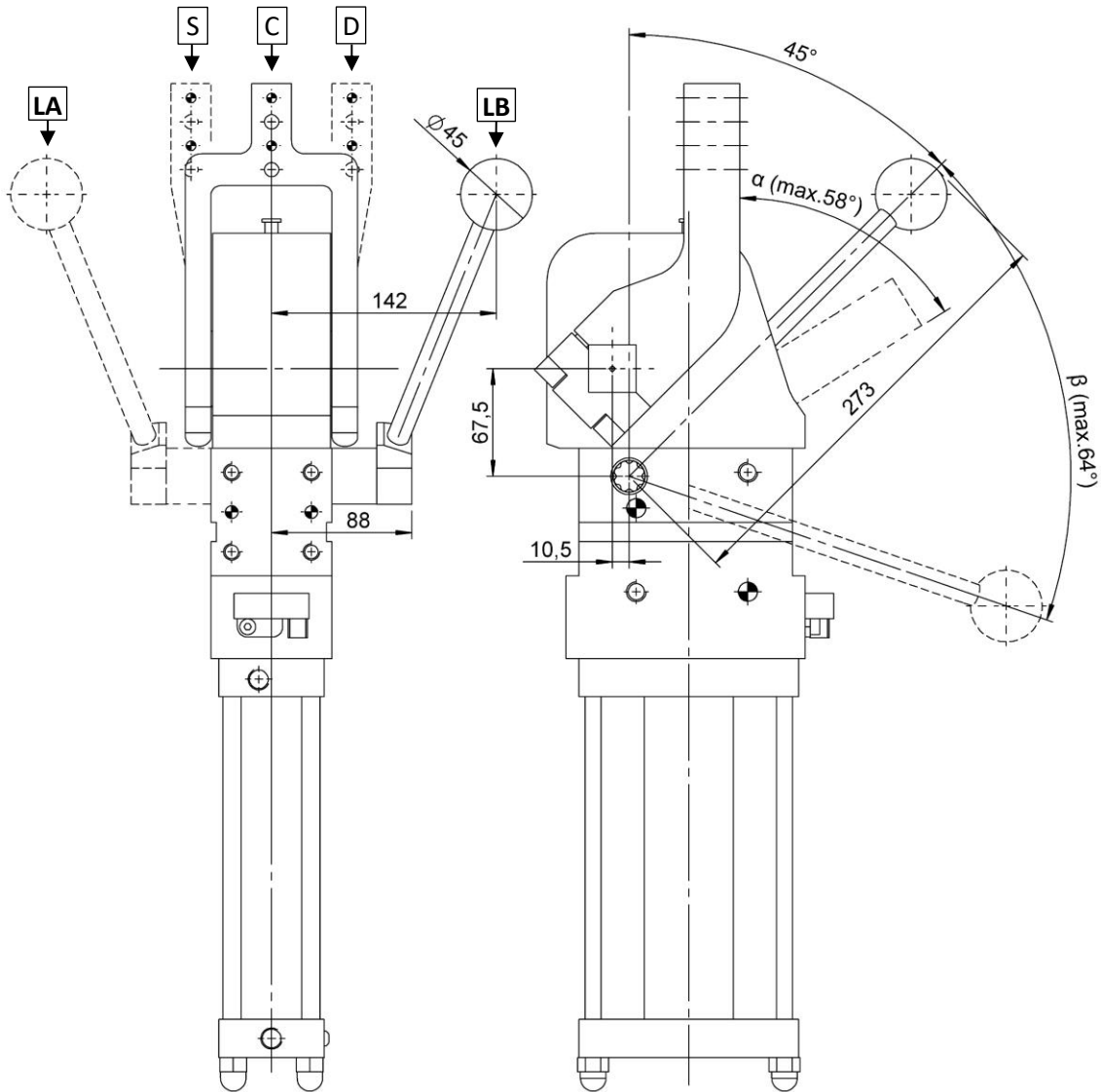

| | | | | |
|----------|-----|-----|-----|-----|
| α | 16° | 29° | 43° | 58° |
| β | 37° | 46° | 55° | 64° |

Control manual ajustable en pasos de 22,5°
 Manual control adjustable in steps of 22,5°

#Tolerancias: barrenos ± 0.02 , orificios de tornillo ± 0.1
 # Tolerances: dowel holes ± 0.02 , screw holes ± 0.1

| Tipo Type | Diámetro del cilindro Cylinder bore | Momento de retención Holding moment | Peso Weight | Presión de trabajo Working pressure | Max. fuerza manual Max. manual force |
|------------------|--|--|----------------|--|---|
| | [mm] | [Nm] | [Kg] | [bar] | [N] |
| CPLM80L...H3...S | 80 | 2500 | ~ 16,5 | 4 – 8 | 200 |



Diagramas CPL80.

Diagrams CPL80.

Esfuerzo de torsión de sujeción(Nm)

Clamping torque (Nm)

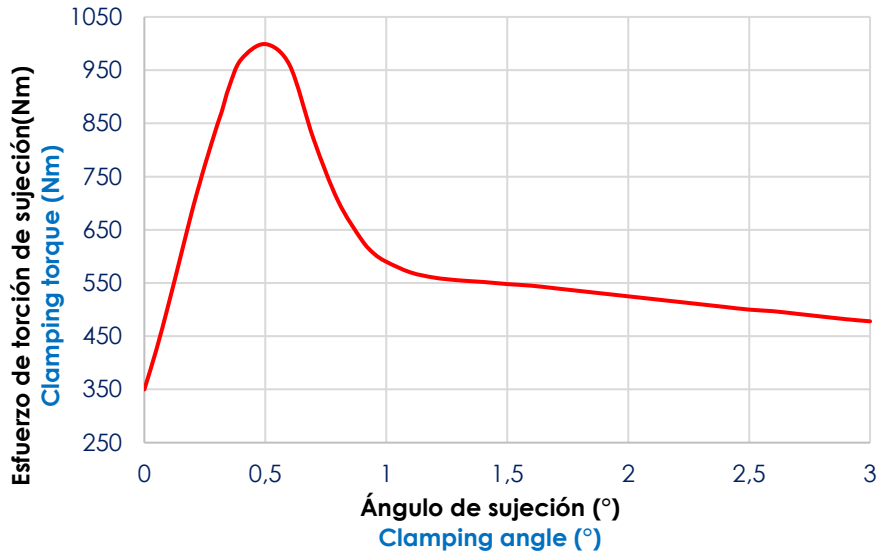

Esfuerzo máximo de torsión (5 barras): **1000 Nm.**

Max. clamping torque (5 bar): **1000 Nm.**

Carga máxima aplicable al brazo (Kg) a 5 bar.

Max. load applicable on the arm (Kg) at 5 bar.

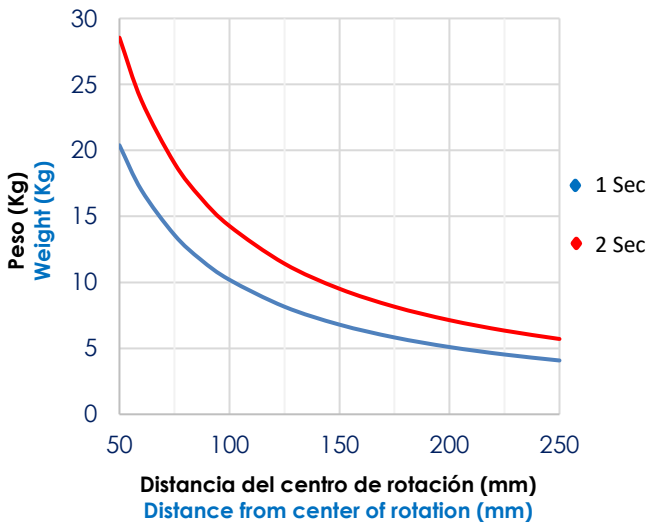

Máxima fuerza aplicada (N) a 5 bar.

Max. force applied (N) at 5 bar.

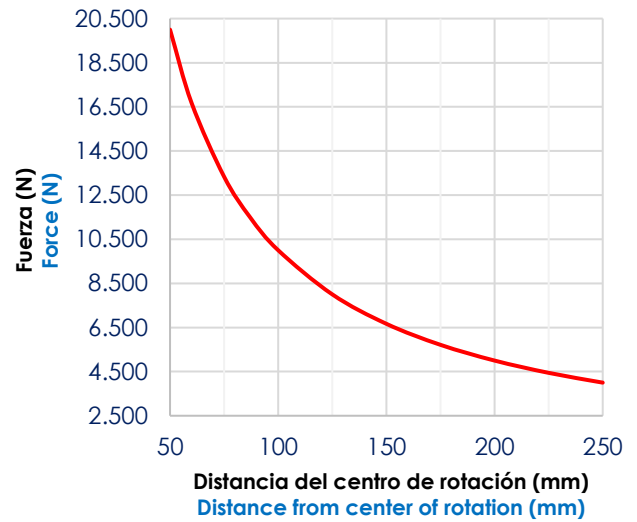

| Tipo Type | Max. esfuerzo de torsión Por peso Max. torque By weight [Nm] | | El par máximo para aplicaciones con la carga fuera del eje The max torque for applications with the load out of axis [Nm] | |
|--------------|--|-------|---|-------|
| | 1 sec | 2 sec | 1 sec | 2 sec |
| CPL 80 | 10 | 14 | 7,5 | 10,5 |



Diagrama del interruptor de proximidad inductivo M12 (cod. 09960/L/C).

Diagram for M12 inductive proximity switch (cod. 09960/L/C).

Datos técnicos:

- Tipo de salida: PNP;
- Voltaje de alimentación: 10-30 VDC;
- Máxima corriente de conmutación: 150 mA;
- Fuente de alimentación: < 20 mA;
- Caída de voltaje: < 1,8 V
- Rango de temperatura: -25° / 70° C.

Technical data:

- Output type: PNP;
- Feeding voltage: 10-30 VDC;
- Max. commutating current: 150 mA;
- Power supply: < 20 mA;
- Voltage drop: < 1,8 V;
- Temperature range: -25° / 70° C.

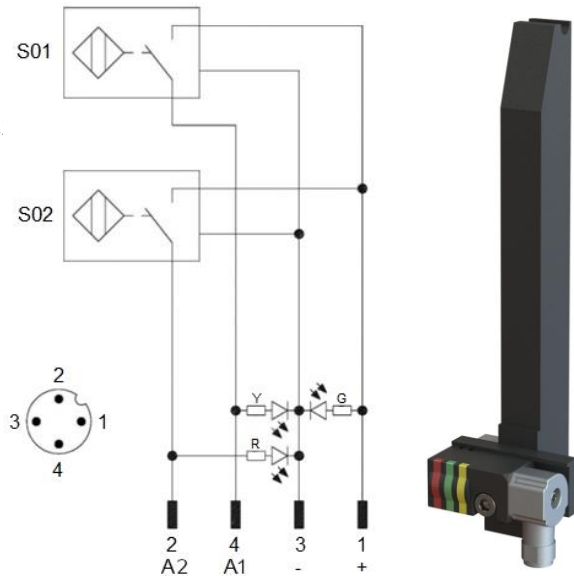

S01 = Señal de apertura
S01 = opening signal
S02 = Señal de cierre
S02 = closing signal

Y = LED amarillo / yellow LED
G = LED verde / green LED
R = LED rojo / red LED

1 = Cable marrón / brown wire
2 = Cable negro / black wire
3 = Cable azul / blue wire
4 = Cable blanco / white wire

Diagrama neumático.

Pneumatic plan.

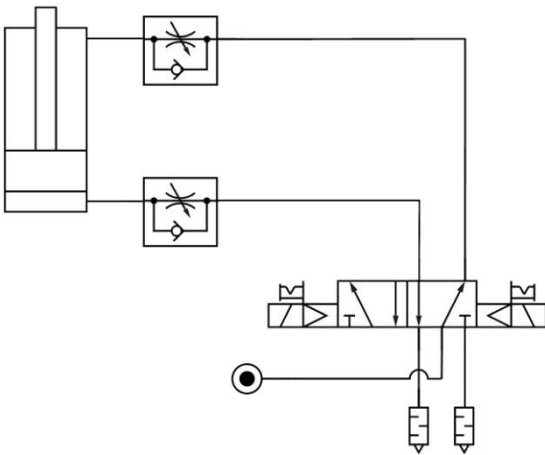

| | | | | | | | |
|---|-----------------------------|--|--|--|--|--|--|
| Cilindro neumático pneumatic cylinder | Pos. Cerrada closed pos. | | | | | | |
| | Pos. abierta open pos. | | | | | | |
| señal de posición abierta open pos. signal | 1 | | | | | | |
| | 0 | | | | | | |
| señal de posición cerrada closed pos. signal | 1 | | | | | | |
| | 0 | | | | | | |



Instrucciones de operación.

Operating instructions.

Modifica ángulo de apertura.

- Lleve el brazo de la mordaza a la posición de apertura y desenrosque el tornillo M6 que fija el sensor; (imagen 1)
- Siga uno de los siguientes métodos para cambiar el ángulo de apertura:
 - 1) Llevar un tornillo M6 de min.40mm en contacto con el acoplamiento dentado y enroscarlo hasta liberar el sistema (~4 vueltas); (imagen 2)
 - 2) Introducir una llave de Ø máx. 5 mm en el orificio y empujar el resorte aplicando una fuerza $\geq 200\text{N}$; (imagen 3)
- Siga empujando el resorte y mueva el brazo de sujeción manualmente a la posición deseada.
- Suelte el resorte para permitir el acoplamiento automático de los componentes.
- Para el montaje siga el procedimiento descrito anteriormente en orden inverso.

Opening angle change.

- Bring the clamp arm in the opening position and unscrew the M6 bolt that fixes the sensor; (pic 1)
- Follow one of the following methods to change the opening angle:
 - 1) Bring a M6 screw of min.40mm in contact with the toothed coupling and screw it until the system is released (~4 turns); (pic 2)
 - 2) Put a key with $\text{Ø max.}5\text{ mm}$ into the hole, and push the spring applying a force $\geq 200\text{N}$; (pic 3)
- Keep pushing on the spring and move the clamp arm manually to the desired position.
- Release the spring to allow the automatic coupling of the components.
- for assembly follow the procedure described above in reverse order.



Imagen 1
Pic 1



Imagen 2
Pic 2

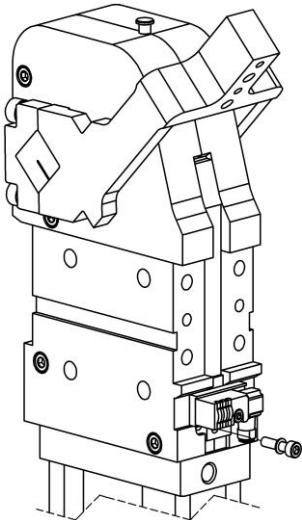

Imagen 3
Pic 3

Ángulos de apertura

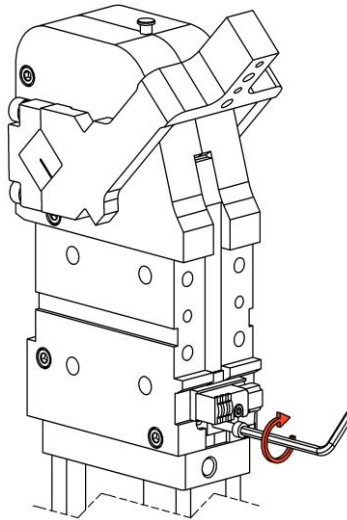
Opening angles.

| Tipo Type | Ángulos de apertura / Opening angles | | | | | | | | | | | | | | | | | | | | | | | | | | | | | | | |
|----------------------|--------------------------------------|---|---|----|----|----|----|----|----|----|----|----|----|----|----|----|----|----|----|----|----|----|----|----|-----|-----|-----|-----|-----|-----|-----|--|
| | 3 | 5 | 7 | 10 | 13 | 16 | 20 | 24 | 29 | 33 | 38 | 43 | 48 | 53 | 58 | 63 | 68 | 72 | 77 | 81 | 86 | 90 | 95 | 99 | 103 | 107 | 112 | 117 | 122 | 127 | 135 | |
| CPL...V1 CPL...V3 | • | • | • | • | • | • | • | • | • | • | • | • | • | • | • | • | • | • | • | • | • | • | • | • | • | • | • | • | • | • | • | |
| CPL...H1 | • | • | • | • | • | • | • | • | • | • | • | • | • | • | • | • | • | • | • | • | • | • | • | • | • | • | | | | | | |
| CPL...H3 | • | • | • | • | • | • | • | • | • | • | • | • | • | • | • | • | • | • | • | • | • | • | • | • | • | • | • | • | | | | |
| CPL...V1...S | • | • | • | • | • | | | | | | | | | | | | | | | | | | | | | | | | | | | |
| CPLV3...S | • | • | • | • | • | • | • | • | • | | | | | | | | | | | | | | | | | | | | | | | |
| CPL...H1...S | • | • | • | • | • | • | • | • | • | • | • | • | • | • | • | • | • | • | • | • | • | • | • | • | • | • | | | | | | |
| CPL...H3...S | • | • | • | • | • | • | • | • | • | • | • | • | • | • | • | • | • | • | • | • | • | • | • | • | • | • | • | | | | | |

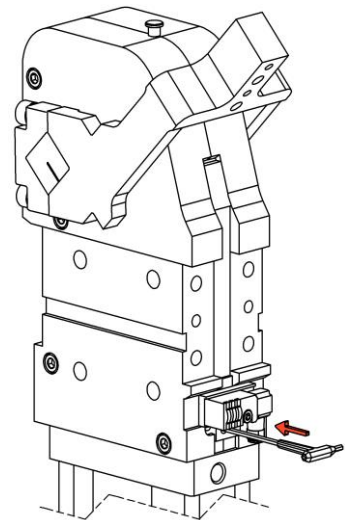

| Tipo Type | Ángulos de apertura / Opening angles | | | | | | | | | | | | | | | | | | | | | | | | | | | | |
|------------------------|--------------------------------------|---|---|----|----|----|----|----|----|----|----|----|----|----|----|----|----|----|----|----|----|----|----|----|-----|-----|-----|-----|-----|
| | 3 | 5 | 7 | 10 | 13 | 16 | 20 | 24 | 29 | 33 | 38 | 43 | 48 | 53 | 58 | 63 | 68 | 72 | 77 | 81 | 86 | 90 | 95 | 99 | 103 | 107 | 112 | 117 | 122 |
| CPLM...V1 CPLM...V3 | • | • | • | • | • | • | • | • | • | • | • | • | • | • | • | • | • | • | • | • | • | • | • | • | • | • | • | • | • |
| CPLM...H1 | • | • | • | • | • | • | • | • | • | • | • | • | • | • | • | • | • | • | • | • | • | • | • | • | • | • | • | • | • |
| CPLM...H3 | • | • | • | • | • | • | • | • | • | • | • | • | • | • | • | • | • | • | • | • | • | • | • | • | • | • | • | • | • |
| CPLM...V1...S | • | • | • | • | • | | | | | | | | | | | | | | | | | | | | | | | | |
| CPLM...V3...S | • | • | • | • | • | • | • | • | • | | | | | | | | | | | | | | | | | | | | |
| CPLM...H1...S | • | • | • | • | • | • | • | • | • | • | • | • | • | • | • | • | • | • | • | • | • | • | • | • | • | • | • | • | |
| CPLM...H3...S | • | • | • | • | • | • | • | • | • | • | • | • | • | • | • | • | • | • | • | • | • | • | • | • | • | • | • | • | |

Piezas de repuesto.

Spare parts.

| # Kit | Imagen Picture | Descripción Description | Artículo Article |
|---|-------------------|--|---------------------|
| Grupo de brazos Arm assembly | | Brazo V1C / H1C / V1CS / H1CS Arm V1C / H1C / V1CS / H1CS | 06635/C |
| | | Brazo V1D / H1S / V1SS / H1DS Arm V1D / H1S / V1SS / H1DS | 06656/DX/C |
| | | Brazo V1S / H1D / V1DS / H1SS Arm V1S / H1D / V1DS / H1SS | 06656/SX/C |
| | | Brazo tipo V1CDS y O1CDS Arm type V1CDS and O1CDS | 06656/CDS/C |
| | | Brazo V3C / H3C / V3CS / H3CS Arm V3C / H3C / V3CS / H3CS | 10029/C |
| | | Brazo V3D / H3S / V3SS / H3DS Arm V3D / H3S / V3SS / H3DS | 10029/DX/C |
| | | Brazo V3S / H3D / V3DS / H3SS Arm V3S / H3D / V3DS / H3SS | 10029/SX/C |
| Interruptor de proximidad Proximity switch | | Interruptor de proximidad inductivo VEP (0°-90°) Inductive proximity switch VEP (0°-90°) | 09960/L/C |
| Kit de juntas Seals kit | | Componentes de sellado para cilindro neumático Seal components for pneumatic cylinder | SCR-CPL80 |

